

BMA6002; BMI6002

Battery management communication gateway

Rev. 2.0 — 21 May 2026

Short data sheet

1 Product profile

1.1 General description

The BMx6002 is a general-purpose battery management wired communication gateway and transport protocol link (TPL) transceiver. The TPL is the proprietary bidirectional isolated daisy chain protocol of NXP via a single twisted-pair cable. The BMx6002 forwards requests from a standard microcontroller communication interface (MCU interface) to the TPL ports. Messages from the TPL ports are routed back to the MCU interface. Supported MCU communication types are serial peripheral interface (SPI) or controller area network flexible data rate (CAN FD).

The BMx6002S communicates directly to the MCU by using SPI. The BMx6002C powers an external CAN transceiver to be a part of a CAN bus. The standard communication protocols ensure compatibility with most microcontrollers available in the market.

The BMx6002 provides two TPL daisy chain ports to communicate with other BMS devices in the daisy chain. Each daisy chain port supports capacitive and inductive isolated communication.

The two daisy chain ports use the same protocol and ensure interoperability with NXP battery management devices like MC33774AT, BMA7118, and MC33775A or battery monitoring devices like MC33777.

The BMx6002 supports the ASIL D compliant communication protocol and is AEC-Q100 grade 1 qualified (only BMA6002).

1.2 Features and benefits

- MCU host interface supporting SPI or CAN (FD)
 - SPI (BMx6002S)
 - Single or dual SPI mode
 - Up to 10 Mbit/s data rate
 - CAN (FD) (BMx6002C)
 - CAN with up to 1 Mbit/s data rate
 - CAN FD with up to 1 Mbit/s arbitration and up to 5 Mbit/s data rate
 - Selectable I/O voltage of 5 V or 3.3 V
- Serial interfaces to control external devices, for example, EEPROMs and security ICs
 - SPI controller interface with up to 4 or 6 configurable chip select outputs
 - I²C-bus controller interface
- Message buffering
 - Configurable response and request buffers
 - Status/handshake signals for data flow control
- Communication management unit
 - Error detection and reporting
- Multipoint TPL interface
 - Two independent TPL daisy chain ports with integrated transceiver
 - Automatic message routing based on address of TPL message



- Protocol supporting up to six TPL daisy chains and 62 nodes per chain
- Each daisy chain features
 - 2 Mbit/s data rate (typ.)
 - Two-wire daisy chain supporting capacitive or inductive isolation
 - Loopback support
 - Support for broadcast messages toward multiple chains
- Compatible with TPL3 based products (for example MC33774A, MC33777, BMA7118, or MC33775A)
- Power supply
 - Supply via external 5 V regulator or integrated 5 V regulator
 - Integrated 5 V regulator with operating range 5.5 V to 18 V
 - Power mode management of the external CAN (FD) transceiver
- Operation modes
 - Active mode
 - Sleep mode (25 μ A typ.)
- Wake-up of the device by
 - TPL daisy chain (reverse wake-up)
 - MCU communication
 - Wake-up input (for example, external sensor information)
- Internal oscillator and external clock reference (external crystal or external clock signal) supported
- General-purpose inputs/outputs (GPIOs) with assignable status and events
- Unique device ID
- AEC-Q100 grade 1 qualified: $-40\text{ }^{\circ}\text{C}$ to $+125\text{ }^{\circ}\text{C}$ ambient temperature range (only BMA6002)
- Supports ASIL D compliant protocol of NXP due to end-to-end communication protection

2 Ordering information

Table 1. Ordering information

Type number	Package		
	Name	Description	Version
BMA6002S	LQFP48	plastic, low profile quad flat leaded package; 48 terminals; 0.50 mm pitch; 7 × 7 × 1.4 mm body	SOT1571-1
BMI6002S	LQFP48	plastic, low profile quad flat leaded package; 48 terminals; 0.50 mm pitch; 7 × 7 × 1.4 mm body	SOT1571-1
BMA6002C	LQFP48	plastic, low profile quad flat leaded package; 48 terminals; 0.50 mm pitch; 7 × 7 × 1.4 mm body	SOT1571-1
BMI6002C	LQFP48	plastic, low profile quad flat leaded package; 48 terminals; 0.50 mm pitch; 7 × 7 × 1.4 mm body	SOT1571-1

3 Block diagram

Figure 1 and Figure 2 show the general architecture of the BMx6002 versions.

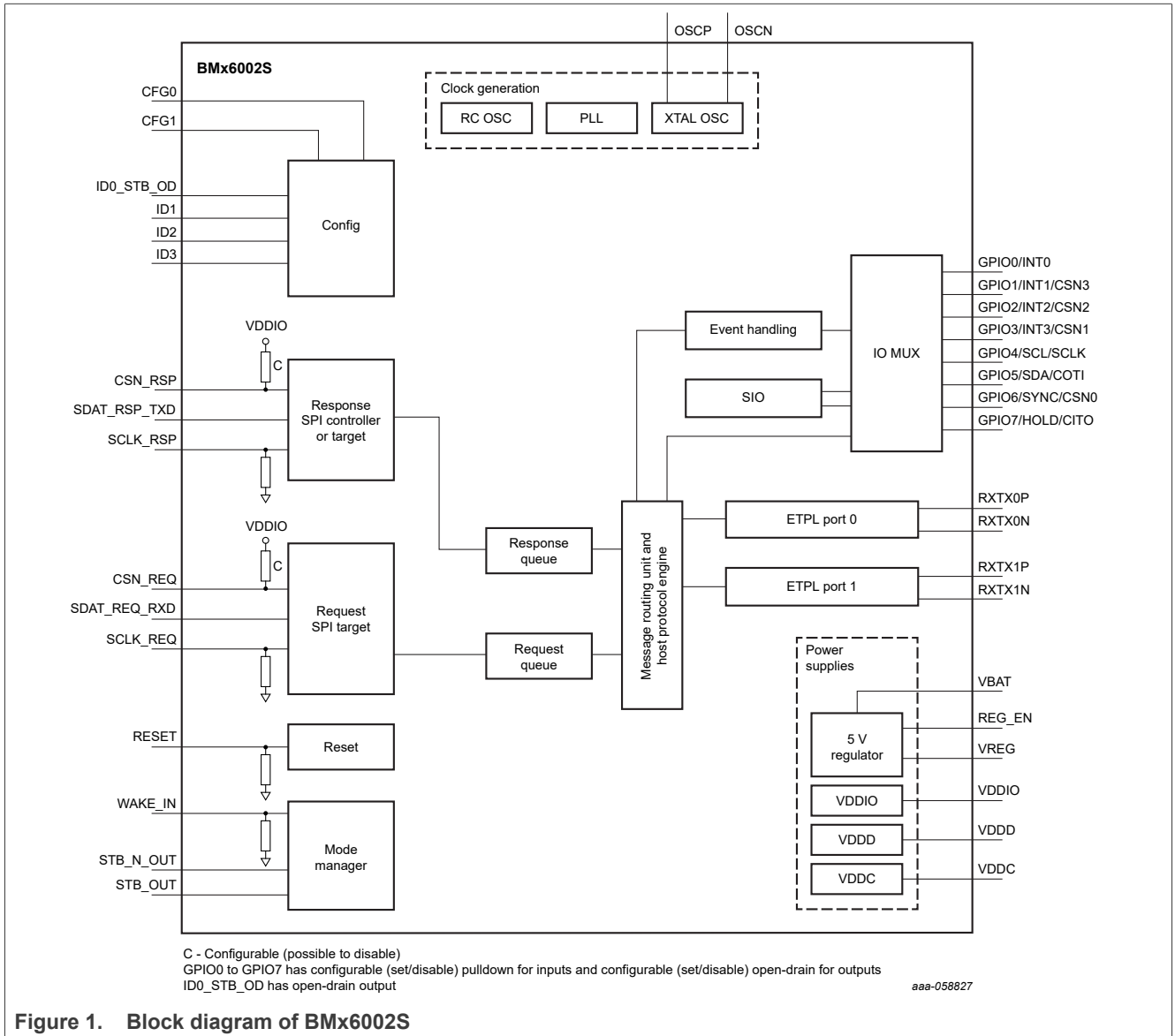

Figure 1. Block diagram of BMx6002S

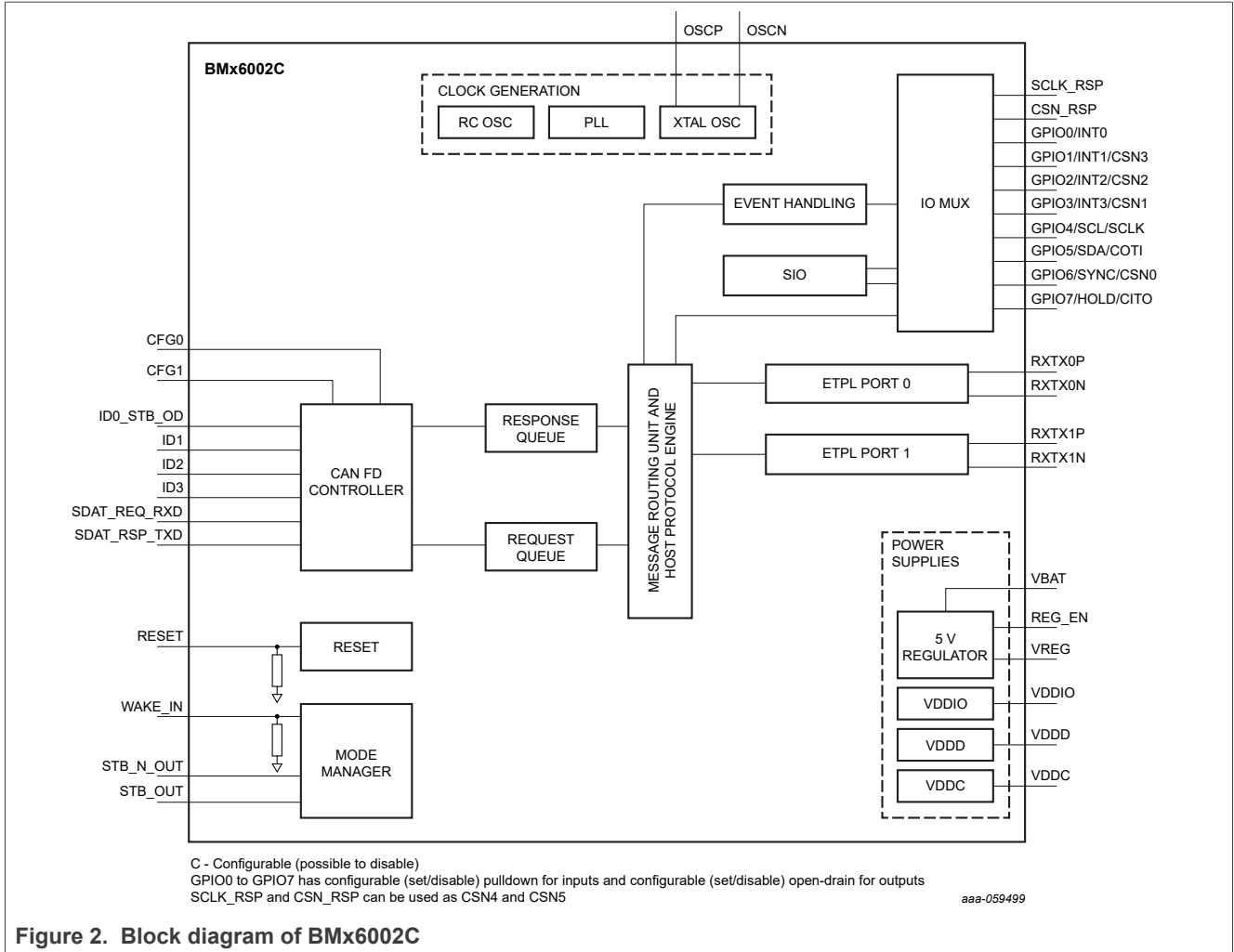

Figure 2. Block diagram of BMx6002C

4 Limiting values

Table 2. Limiting values

In accordance with the Absolute Maximum Rating System (IEC 60134).

Symbol	Parameter	Conditions	Min	Typ	Max	Unit
$V_{i(VBAT)}$	input voltage on pin VBAT		-0.3	-	+40	V
V_{REG_EN}	voltage on pin REG_EN		-0.3	-	min ($V_{i(VBAT)}$ + 0.5, +40)	V
$V_{O(VREG)}$	output voltage on pin VREG		-0.3	-	+5.8	V
$V_{I(VDDD)}$	input voltage on pin VDDD		-0.3	-	+5.8	V
$V_{I(VDDC)}$	input voltage on pin VDDC		-0.3	-	+5.8	V
$V_{I(VDDIO)}$	input voltage on pin VDDIO		-0.3	-	+5.8	V

Table 2. Limiting values...continued
 In accordance with the Absolute Maximum Rating System (IEC 60134).

Symbol	Parameter	Conditions	Min	Typ	Max	Unit
$V_{I(dig)}$	digital input voltage	GPIO0 to GPIO7, ID1 to ID3, CFG0, CFG1, SDAT_REQ_RXD, SDAT_RSP_TXD, CSN_RSP, CSN_REQ, SCLK_REQ, SCLK_RSP, STB_N_OUT, STB_OUT	-0.3	-	min ($V_{VDDIO} + 0.5$, 5.8)	V
$V_{I(dig)}$	digital input voltage	ID0_STB_OD for CAN FD	-0.3	-	min ($V_{VDDIO} + 0.5$, 5.8)	V
$V_{I(dig)}$	digital input voltage	ID0_STB_OD for SPI or UART	-0.3	-	+5.8	V
$V_{I(WAKE_IN)}$	input voltage on pin WAKE_IN		-0.3	-	min ($V_{I(VBAT)} + 0.5$, +40)	V
$V_{i(OSCP)}$	input voltage on pin OSCP		-0.3	-	+5.8	V
$V_{i(OSCN)}$	input voltage on pin OSCN		-0.3	-	+2.75	V
$V_{bus(TPL)}$	voltage on TPL communication bus pins	RXTX0N, RXTX0P, RXTX1N, RXTX1P; relative to pin VSSC	-10	-	+10	V
$V_{I(RESET)}$	input voltage on pin RESET	maximum limits	-0.3	-	+5.8	V
ESD maximum ratings						
V_{ESD1}	electrostatic discharge voltage 1	at any pin; human body model (HBM): according to AEC-Q100-002 (100 pF, 1.5 k Ω)	-2	-	+2	kV
V_{ESD2}	electrostatic discharge voltage 2	at VSSIO, ID0_STB_OD, ID1, ID2, ID3, VSSC, RXTX1P, RXTX1N, GNDSUB, RXTX0P, RXTX0N, WAKE_IN, REG_EN, VBAT, VSSD, CFG1, CFG0; HBM: according to AEC-Q100-002 (100 pF, 1.5 k Ω)	-4	-	+4	kV
V_{ESD3}	electrostatic discharge voltage 3	at all pins; charged device model (CDM): according to AEC-Q100-011 (field induced charge; 4 pF)	-500	-	+500	V
V_{ESD4}	electrostatic discharge voltage 4	at corner pins; CDM: according to AEC-Q100-011 (field induced charge; 4 pF)	-750	-	+750	V
Thermal maximum ratings						
T_j	junction temperature		-40	-	+165	$^{\circ}\text{C}$
T_{stg}	storage temperature		-55	-	+150	$^{\circ}\text{C}$

Table 2. Limiting values...continued

In accordance with the Absolute Maximum Rating System (IEC 60134).

Symbol	Parameter	Conditions	Min	Typ	Max	Unit
$T_{\text{reflow(peak)}}$	peak reflow temperature	[1]	-	-	260	°C

[1] Pin soldering temperature limit is maximum 10 s duration. Not designed for immersion soldering. Exceeding these limits may cause a malfunction or permanent damage to the device.

5 Revision history

Table 3. Revision history

Document ID	Release date	Description
BMA6002_BMI6002_SDS v.2.0	21 May 2026	change to public version
BMA6002_BMI6002_SDS v.1.0	31 March 2025	initial version

Legal information

Data sheet status

Document status ^{[1][2]}	Product status ^[3]	Definition
Objective [short] data sheet	Development	This document contains data from the objective specification for product development.
Preliminary [short] data sheet	Qualification	This document contains data from the preliminary specification.
Product [short] data sheet	Production	This document contains the product specification.

- [1] Please consult the most recently issued document before initiating or completing a design.
- [2] The term 'short data sheet' is explained in section "Definitions".
- [3] The product status of device(s) described in this document may have changed since this document was published and may differ in case of multiple devices. The latest product status information is available on the Internet at URL <https://www.nxp.com>.

Definitions

Draft — A draft status on a document indicates that the content is still under internal review and subject to formal approval, which may result in modifications or additions. NXP Semiconductors does not give any representations or warranties as to the accuracy or completeness of information included in a draft version of a document and shall have no liability for the consequences of use of such information.

Short data sheet — A short data sheet is an extract from a full data sheet with the same product type number(s) and title. A short data sheet is intended for quick reference only and should not be relied upon to contain detailed and full information. For detailed and full information see the relevant full data sheet, which is available on request via the local NXP Semiconductors sales office. In case of any inconsistency or conflict with the short data sheet, the full data sheet shall prevail.

Product specification — The information and data provided in a Product data sheet shall define the specification of the product as agreed between NXP Semiconductors and its customer, unless NXP Semiconductors and customer have explicitly agreed otherwise in writing. In no event however, shall an agreement be valid in which the NXP Semiconductors product is deemed to offer functions and qualities beyond those described in the Product data sheet.

Disclaimers

Limited warranty and liability — Information in this document is believed to be accurate and reliable. However, NXP Semiconductors does not give any representations or warranties, expressed or implied, as to the accuracy or completeness of such information and shall have no liability for the consequences of use of such information. NXP Semiconductors takes no responsibility for the content in this document if provided by an information source outside of NXP Semiconductors.

In no event shall NXP Semiconductors be liable for any indirect, incidental, punitive, special or consequential damages (including - without limitation - lost profits, lost savings, business interruption, costs related to the removal or replacement of any products or rework charges) whether or not such damages are based on tort (including negligence), warranty, breach of contract or any other legal theory.

Notwithstanding any damages that customer might incur for any reason whatsoever, NXP Semiconductors' aggregate and cumulative liability towards customer for the products described herein shall be limited in accordance with the Terms and conditions of commercial sale of NXP Semiconductors.

Right to make changes — NXP Semiconductors reserves the right to make changes to information published in this document, including without limitation specifications and product descriptions, at any time and without notice. This document supersedes and replaces all information supplied prior to the publication hereof.

Applications — Applications that are described herein for any of these products are for illustrative purposes only. NXP Semiconductors makes no representation or warranty that such applications will be suitable for the specified use without further testing or modification.

Customers are responsible for the design and operation of their applications and products using NXP Semiconductors products, and NXP Semiconductors accepts no liability for any assistance with applications or customer product design. It is customer's sole responsibility to determine whether the NXP Semiconductors product is suitable and fit for the customer's applications and products planned, as well as for the planned application and use of customer's third party customer(s). Customers should provide appropriate design and operating safeguards to minimize the risks associated with their applications and products.

NXP Semiconductors does not accept any liability related to any default, damage, costs or problem which is based on any weakness or default in the customer's applications or products, or the application or use by customer's third party customer(s). Customer is responsible for doing all necessary testing for the customer's applications and products using NXP Semiconductors products in order to avoid a default of the applications and the products or of the application or use by customer's third party customer(s). NXP does not accept any liability in this respect.

Limiting values — Stress above one or more limiting values (as defined in the Absolute Maximum Ratings System of IEC 60134) will cause permanent damage to the device. Limiting values are stress ratings only and (proper) operation of the device at these or any other conditions above those given in the Recommended operating conditions section (if present) or the Characteristics sections of this document is not warranted. Constant or repeated exposure to limiting values will permanently and irreversibly affect the quality and reliability of the device.

Terms and conditions of commercial sale — NXP Semiconductors products are sold subject to the general terms and conditions of commercial sale, as published at <https://www.nxp.com/profile/terms>, unless otherwise agreed in a valid written individual agreement. In case an individual agreement is concluded only the terms and conditions of the respective agreement shall apply. NXP Semiconductors hereby expressly objects to applying the customer's general terms and conditions with regard to the purchase of NXP Semiconductors products by customer.

No offer to sell or license — Nothing in this document may be interpreted or construed as an offer to sell products that is open for acceptance or the grant, conveyance or implication of any license under any copyrights, patents or other industrial or intellectual property rights.

Quick reference data — The Quick reference data is an extract of the product data given in the Limiting values and Characteristics sections of this document, and as such is not complete, exhaustive or legally binding.

Export control — This document as well as the item(s) described herein may be subject to export control regulations. Export might require a prior authorization from competent authorities.

HTML publications — An HTML version, if available, of this document is provided as a courtesy. Definitive information is contained in the applicable document in PDF format. If there is a discrepancy between the HTML document and the PDF document, the PDF document has priority.

Translations — A non-English (translated) version of a document, including the legal information in that document, is for reference only. The English version shall prevail in case of any discrepancy between the translated and English versions.

Security — Customer understands that all NXP products may be subject to unidentified vulnerabilities or may support established security standards or specifications with known limitations. Customer is responsible for the design and operation of its applications and products throughout their lifecycles to reduce the effect of these vulnerabilities on customer's applications and products. Customer's responsibility also extends to other open and/or proprietary technologies supported by NXP products for use in customer's applications. NXP accepts no liability for any vulnerability. Customer should regularly check security updates from NXP and follow up appropriately. Customer shall select products with security features that best meet rules, regulations, and standards of the intended application and make the ultimate design decisions regarding its products and is solely responsible for compliance with all legal, regulatory, and security related requirements concerning its products, regardless of any information or support that may be provided by NXP.

NXP has a Product Security Incident Response Team (PSIRT) (reachable at PSIRT@nxp.com) that manages the investigation, reporting, and solution release to security vulnerabilities of NXP products.

Suitability for use in automotive applications (functional safety) —

This NXP product has been qualified for use in automotive applications. It has been developed in accordance with ISO 26262, and has been ASIL classified accordingly. If this product is used by customer in the development of, or for incorporation into, products or services (a) used in safety critical applications or (b) in which failure could lead to death, personal injury, or severe physical or environmental damage (such products and services hereinafter referred to as "Critical Applications"), then customer makes the ultimate design decisions regarding its products and is solely responsible for compliance with all legal, regulatory, safety, and security related requirements concerning its products, regardless of any information or support that may be provided by NXP. As such, customer assumes all risk related to use of any products in Critical Applications and NXP and its suppliers shall not be liable for any such use by customer. Accordingly, customer will indemnify and hold NXP harmless from any claims, liabilities, damages and associated costs and expenses (including attorneys' fees) that NXP may incur related to customer's incorporation of any product in a Critical Application.

NXP B.V. — NXP B.V. is not an operating company and it does not distribute or sell products.

Licenses

Purchase of NXP ICs with NFC technology — Purchase of an NXP Semiconductors IC that complies with one of the Near Field Communication (NFC) standards ISO/IEC 18092 and ISO/IEC 21481 does not convey an implied license under any patent right infringed by implementation of any of those standards. Purchase of NXP Semiconductors IC does not include a license to any NXP patent (or other IP right) covering combinations of those products with other products, whether hardware or software.

Trademarks

Notice: All referenced brands, product names, service names, and trademarks are the property of their respective owners.

NXP — wordmark and logo are trademarks of NXP B.V.

Tables

Tab. 1.	Ordering information	3	Tab. 3.	Revision history	7
Tab. 2.	Limiting values	5			

Figures

Fig. 1.	Block diagram of BMx6002S	4	Fig. 2.	Block diagram of BMx6002C	5
---------	---------------------------------	---	---------	---------------------------------	---

Contents

1	Product profile	1
1.1	General description	1
1.2	Features and benefits	1
2	Ordering information	3
3	Block diagram	4
4	Limiting values	5
5	Revision history	7
	Legal information	8

Please be aware that important notices concerning this document and the product(s) described herein, have been included in section 'Legal information'.
