

# Addendum to MC9S08GB60, MC9S08GB32, MC9S08GT60, MC9S08GT32, MC9S08GT16 Data Sheet

This addendum provides the following changes to the MC9S08GB60, MC9S08GB32, MC9S08GT60, MC9S08GT32, and MC9S08GT16 Data Sheet (Freescale Semiconductor order number MC9S08GB60/D):

- Relace Table A-4 DC Characteristics with the new table found on page 2 of this Addendum
- Replace the MC9S08GTxx Block Diagram with the diagram found on the page 3 of this Addendum.

**Table A-4 DC Characteristics**  
(Temperature Range = -40 to 85°C Ambient)

Parameter	Symbol	Min	Typical <sup>1</sup>	Max	Unit
Low-voltage detection threshold — high range (V <sub>DD</sub> falling) (V <sub>DD</sub> rising)	V <sub>LVDH</sub>	2.08 2.16	2.1 2.19	2.2 2.27	V
Low-voltage detection threshold — low range (V <sub>DD</sub> falling) (V <sub>DD</sub> rising)	V <sub>LVDL</sub>	1.80 1.88	1.82 1.90	1.91 1.99	V
Low-voltage warning threshold — high range (V <sub>DD</sub> falling) (V <sub>DD</sub> rising)	V <sub>LVWH</sub>	2.35 2.35	2.40 2.40	2.5 —	V
Low-voltage warning threshold — low range (V <sub>DD</sub> falling) (V <sub>DD</sub> rising)	V <sub>LVWL</sub>	2.08 2.16	2.1 2.19	2.2 2.27	V

<sup>1</sup> Typicals are measured at 25°C.

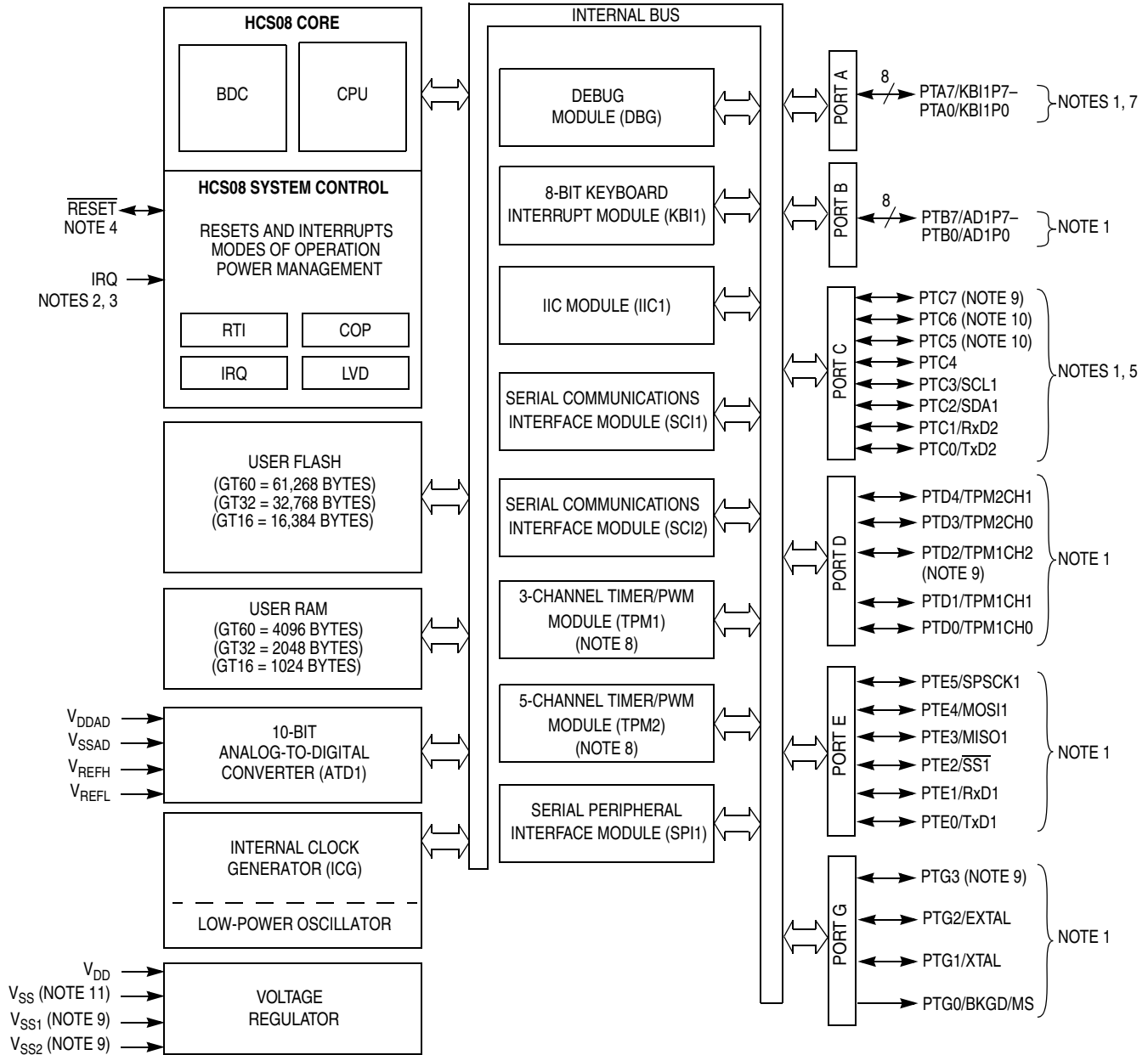

**NOTES:**

1. Port pins are software configurable with pullup device if input port.
2. Pin contains software configurable pullup/pulldown device if IRQ enabled (IRQPE = 1).
3. IRQ does not have a clamp diode to V<sub>DD</sub>. IRQ should not be driven above V<sub>DD</sub>.
4. Pin contains integrated pullup device.
5. High current drive
6. PTC[6:5] are not available on the 42-pin SDIP package.
7. Pins PTA[7:4] contain both pullup and pulldown devices. Pulldown available when KBI enabled (KBIPn = 1).
8. Only two timer channels per TPM are bonded out. All channels are available for use as software compare.
9. PTC7, PTD2/TPM1CH2, PTG3, V<sub>SS1</sub>, and V<sub>SS2</sub> are not available on the 44 QFP or 42 SDIP.
10. PTC[6:5] not available on the 42 SDIP.
11. V<sub>SS</sub> is not available on the 48 QFP.

**Figure 1-2. MC9S08GTxx Block Diagram**

## **How to Reach Us:**

### **Home Page:**

[www.freescale.com](http://www.freescale.com)

### **E-mail:**

[support@freescale.com](mailto:support@freescale.com)

### **USA/Europe or Locations Not Listed:**

Freescale Semiconductor  
Technical Information Center, CH370  
1300 N. Alma School Road  
Chandler, Arizona 85224  
+1-800-521-6274 or +1-480-768-2130  
[support@freescale.com](mailto:support@freescale.com)

### **Europe, Middle East, and Africa:**

Freescale Halbleiter Deutschland GmbH  
Technical Information Center  
Schatzbogen 7  
81829 Muenchen, Germany  
+44 1296 380 456 (English)  
+46 8 52200080 (English)  
+49 89 92103 559 (German)  
+33 1 69 35 48 48 (French)  
[support@freescale.com](mailto:support@freescale.com)

### **Japan:**

Freescale Semiconductor Japan Ltd.  
Headquarters  
ARCO Tower 15F  
1-8-1, Shimo-Meguro, Meguro-ku,  
Tokyo 153-0064  
Japan  
0120 191014 or +81 3 5437 9125  
[support.japan@freescale.com](mailto:support.japan@freescale.com)

### **Asia/Pacific:**

Freescale Semiconductor Hong Kong Ltd.  
Technical Information Center  
2 Dai King Street  
Tai Po Industrial Estate  
Tai Po, N.T., Hong Kong  
+800 2666 8080  
[support.asia@freescale.com](mailto:support.asia@freescale.com)

### **For Literature Requests Only:**

Freescale Semiconductor Literature Distribution Center  
P.O. Box 5405  
Denver, Colorado 80217  
1-800-441-2447 or 303-675-2140  
Fax: 303-675-2150  
[LDCForFreescaleSemiconductor@hibbertgroup.com](mailto:LDCForFreescaleSemiconductor@hibbertgroup.com)

Information in this document is provided solely to enable system and software implementers to use Freescale Semiconductor products. There are no express or implied copyright licenses granted hereunder to design or fabricate any integrated circuits or integrated circuits based on the information in this document.

Freescale Semiconductor reserves the right to make changes without further notice to any products herein. Freescale Semiconductor makes no warranty, representation or guarantee regarding the suitability of its products for any particular purpose, nor does Freescale Semiconductor assume any liability arising out of the application or use of any product or circuit, and specifically disclaims any and all liability, including without limitation consequential or incidental damages. "Typical" parameters that may be provided in Freescale Semiconductor data sheets and/or specifications can and do vary in different applications and actual performance may vary over time. All operating parameters, including "Typicals", must be validated for each customer application by customer's technical experts. Freescale Semiconductor does not convey any license under its patent rights nor the rights of others. Freescale Semiconductor products are not designed, intended, or authorized for use as components in systems intended for surgical implant into the body, or other applications intended to support or sustain life, or for any other application in which the failure of the Freescale Semiconductor product could create a situation where personal injury or death may occur. Should Buyer purchase or use Freescale Semiconductor products for any such unintended or unauthorized application, Buyer shall indemnify and hold Freescale Semiconductor and its officers, employees, subsidiaries, affiliates, and distributors harmless against all claims, costs, damages, and expenses, and reasonable attorney fees arising out of, directly or indirectly, any claim of personal injury or death associated with such unintended or unauthorized use, even if such claim alleges that Freescale Semiconductor was negligent regarding the design or manufacture of the part.

Freescale™ and the Freescale logo are trademarks of Freescale Semiconductor, Inc. All other product or service names are the property of their respective owners.

© Freescale Semiconductor, Inc. 2006. All rights reserved.

RoHS-compliant and/or Pb-free versions of Freescale products have the functionality and electrical characteristics as their non-RoHS-compliant and/or non-Pb-free counterparts. For further information, see <http://www.freescale.com> or contact your Freescale sales representative.

For information on Freescale's Environmental Products program, go to <http://www.freescale.com/epp>.

Document Number: MC9S08GB60AD

Rev. 1.0

04/2006