

TWR-KL25Z Tower Module

Revision C ERRATA
TWR-KL25Z-ERRATA

Rev. 1.1

1 ERRATA

This document describes errata on the TWR-KL25Z rev. C board as well as their workarounds.

1.1 External jtag usage

1.1.1 Issue description

The usage of level shifters in the communication between the integrated debugger (OpenSDA) and the target MCU (KL25) is needed because the OpenSDA debugger runs at 3.3 volts while the KL25 can run at 3.3 or 1.8 volts. One of the level shifters that is used in the circuit is configured for a fixed direction of communication, which means that when not in use by the OpenSDA, the pin is kept in a fixed state. This fixed state inhibits external debuggers to work when the OpenSDA is powered (by connecting the mini USB connector).

The problematic signal is highlighted below.

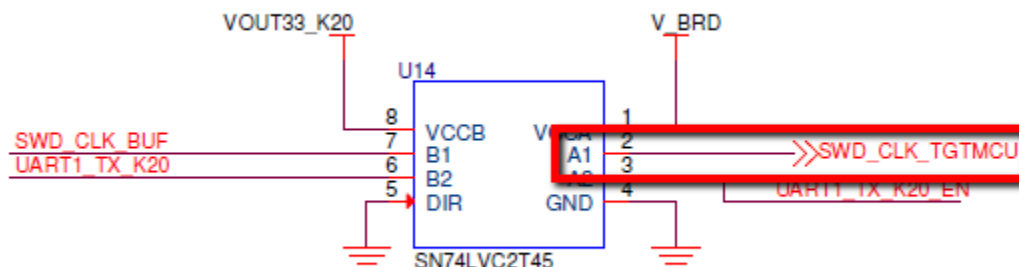

1.1.2 Workaround

To avoid the OpenSDA keeping this signal fixed so that an external debugger can be used, the OpenSDA needs to be unpowered. There are two available ways to power the board without powering the OpenSDA:

- Power through elevators: use the tower elevators and power the board through them.
- Stand-alone through the micro USB: the TWR-KL25Z includes a micro USB connector that is connected to the USB port in the KL25 device. The power input from this USB port is connected to the internal KL25 USB regulator and this regulator output can be routed to power the board by placing to jumpers (J6 and J18) in

the board.

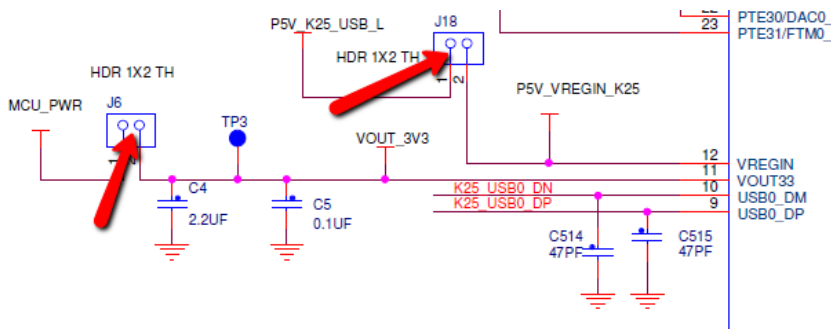

Care should be taken to avoid connecting the OpenSDA mini USB at the same time, because this may cause a short circuit!

1.2 Reset button

When the OpenSDA is not powered the reset button does not work. This is because the reset button has been placed in the OpenSDA side of the level shifter for the reset signal.

To be able to use the reset button, it is needed to power the OpenSDA circuit. This issue does not inhibit the POR or the external debugger reset.

1.3 Pull-ups missing from the TWRPI connector IIC

1.3.1 Issue description

The IIC signals connected to the TWRPI connector (J4, pins 1 and 2) are missing their pull-ups. These signals are also connected to the elevator IIC signals (I2C0_SCL and I2C0_SDA) so they are also missing pull-ups if IIC communication is needed for peripheral boards.

1.3.2 Workaround

Pull-ups can be connected to these signals externally by using the tower elevator lateral connectors. Using through-hole resistors, connect a 2.2 k to 10 k ohm resistor. Connect between pins 7 and 3 and pins 8 and 3 of the primary elevator top lateral connector as showed in the figure below.

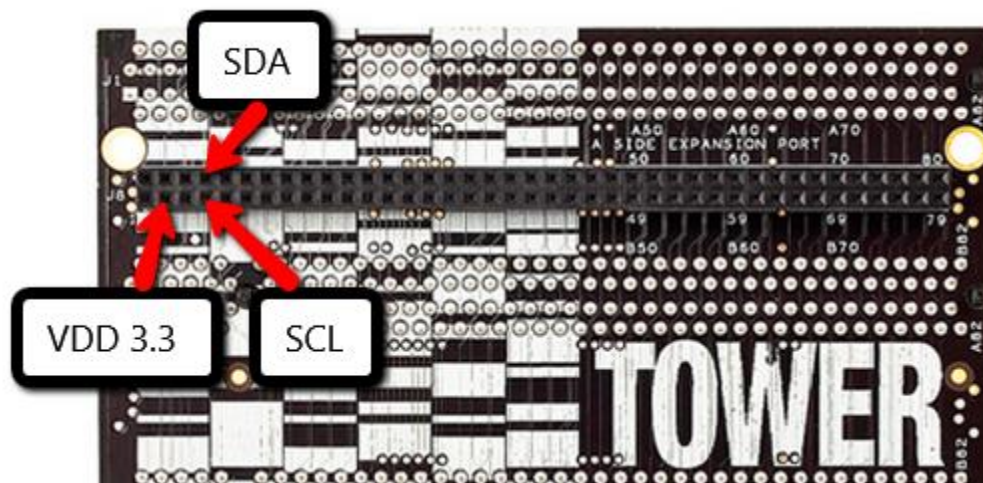

Freescale™ and the Freescale logo are trademarks of Freescale Semiconductor, Inc.
All other product or service names are the property of their respective owners.

© 2013 Freescale Semiconductor, Inc.