

# i.MX 93W applications processor

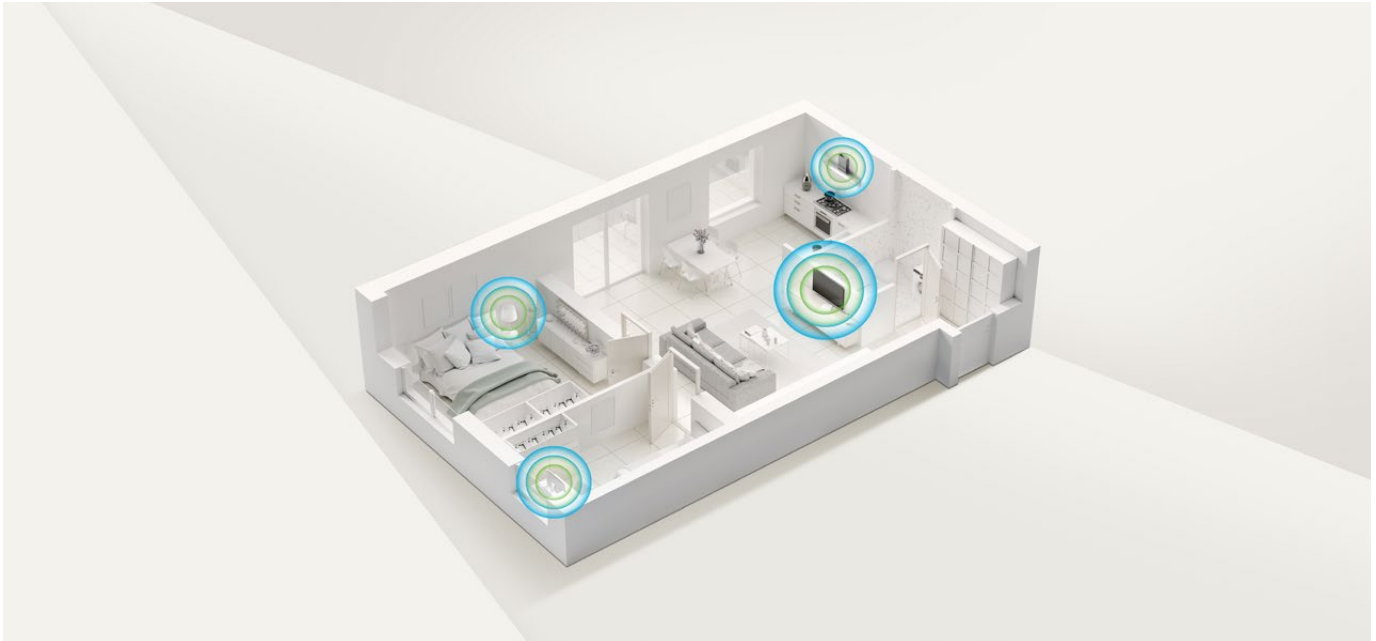

The **i.MX 93W** applications processor combines the proven **i.MX 93** SoC with an integrated IW610 tri-radio (Wi-Fi 6, Bluetooth® Low Energy and 802.15.4), including integrated RF front end, crystal and passives, in a single, compact package, unifying performance compute, AI acceleration and secure connectivity for intelligent connected devices. With a dual core Arm® Cortex®-A55 processor, dedicated AI NPU, integrated IW610 tri-radio wireless subsystem and pre-certified reference designs, i.MX 93W reduces system complexity and accelerates time-to-market for scalable edge AI development across industrial, smart home and energy applications.

## Target applications

- **Industrial automation:** industrial gateways, remote I/O controllers, HMIs, industrial scanners, machine vision systems
- **Smart home:** home hubs, smart thermostats, smart locks, access control systems, video doorbells, connected appliances
- **Building control and smart infrastructure:** lighting controllers, HVAC controllers, occupancy sensors, building automation controllers, smart energy management systems
- **Energy and power:** connected energy meters, EV charging controllers, energy infrastructure monitors, grid edge devices
- **Healthcare:** medical sensors, wearable health devices, smart diagnostic equipment, healthcare gateways
- **Industrial and IoT gateways:** multi-protocol IoT gateways, edge AI controllers, secure wireless aggregation hubs

## Performance compute engine

The i.MX 93W applications processor integrates the scalable Arm Cortex-A55 core, bringing best-in-class performance and energy efficiency to Linux®-based edge applications. Based on Arm's DynamIQ technology, the A55 core features the latest Armv8-A architecture extensions, with dedicated instructions to accelerate machine learning (ML).

## Neural processing unit (NPU)

The i.MX 93W applications processor features the Arm® Ethos™-U65 microNPU. This dedicated neural processing unit (NPU) delivers a combination of performance and efficiency with an optimized area that enables developers to create high performance, cost-effective and energy-efficient ML applications.

## Wireless system integration

The IW610 tri-radio wireless solution integrated into the i.MX 93W delivers Wi-Fi 6, Bluetooth LE and 802.15.4 (Zigbee, Thread/Matter) connectivity in a single, tightly integrated subsystem designed for secure, reliable edge AI deployments. By integrating the radio, RF front end, crystal and passives into the i.MX 93W package, the IW610 eliminates complex RF tuning and coexistence challenges, replaces more than 60 discrete components and enables the use of NXP provided pre-certified single and dual antenna reference designs to significantly reduce design risk and accelerate global wireless certification and time-to-market for industrial, smart home, building automation and energy applications.

## Built-in MCU

The 250 MHz Arm Cortex-M33 processor performs time critical real-time compute and control, eliminating the need for an external microcontroller in the system design. The integrated Cortex-M33 core, paired with CAN FD interface, provides a robust local control network for industrial applications. Additionally, the Cortex-M33 processor can operate in conjunction with the NPU to support wake-word detection.

## Camera interfaces and image processing

The i.MX 93W features MIPI-CSI and parallel camera interfaces, along with an image sensor interface and NPU to support both monochrome and RGB (color) vision applications. The applications processor offers a 2-lane MIPI-CSI camera interface capable of supporting up to 1080p60 resolution and enables direct connection to external camera module and ISP. It also provides image processing capabilities such as down scaling, color space conversion, de-interlacing, alpha insertion, cropping and rotation for machine vision and other ML related applications.

## Display and multimedia

The i.MX 93W applications processor supports a 4-lane MIPI-DSI interface capable of up to 1080p60 resolution, as well as 4-lane LVDS and parallel display interfaces supporting up to 720p60 resolution. It also features a high efficiency pixel pipeline to perform 2D graphics processing, supporting image rotation (90°, 180°, 270°),

image resizing, color space conversion, multiple pixel formats (RGB, YUV444, YUV422, YUV420, YUV400) and standard 2D-DMA operations.

## System security

The i.MX 93W family implements security via NXP's [EdgeLock® secure enclave](#), a preconfigured, self-managed and autonomous security subsystem. EdgeLock eases the complexity of implementing robust, device-wide security intelligence for IoT applications through autonomous management of critical security functions, such as root of trust, run-time attestation, trust provisioning, secure boot, key management and cryptographic services, while also simplifying the path to industry-standard security certifications. The secure enclave functions like a "security HQ" or fortress inside the i.MX 93W, overseeing all security functions to protect systems against physical and network attacks. Fine-grained key management capabilities are augmented by extensive crypto services for advanced attack resistance. The secure enclave also intelligently tracks power transitions when applications are running to help prevent new attack surfaces from emerging. These attacks may include hardware reverse engineering, malware insertion, modifying/replacing the device image, version rollback attacks and physical attacks.

## Enhanced reliability

The i.MX 93 implements error-correcting code (ECC) for most of the internal memories, including the L1, L2, L3 caches of the Arm Cortex-A55, the TCM of the Cortex-M33, the internal on-chip memory and the DDR interface for enhanced reliability.

## Energy flex architecture

For fine-grained power management the i.MX 93W applications processor implements NXP's innovative energy flex architecture where power and clock frequency of heterogenous domains such as the application domain (Cortex-A55s), real-time domain (Cortex-M33, peripherals) and flex domains (NPU, DDR etc.) can be individual controlled to provide the maximum flexibility to achieve lowest power consumption possible tuned to use cases.

## Rich set of high-speed and memory interfaces

The i.MX 93W applications processor supports a rich set of high-speed interfaces for connectivity and fast data transfer, including 2x USB 2.0, 3x SD/SDIO 3.01, 1x CAN FD and 2x Gigabit Ethernet interfaces.. Supported memory interfaces include 16-bit LPDDR4/4X and eMMC 5.1, offering an optimized balance of density, performance and cost.

## Simplified certification path

Leverage NXP provided single and dual antenna reference designs, pre-certified for multiple countries, to reduce RF design risk and streamline wireless certifications for connected devices.

## Comprehensive software support

NXP's Yocto based enablement software provides flexibility to our customers to customize the BSPs to their specific needs. NXP provides quarterly releases with latest and greatest kernel patches and bug fixes to support the customers in their design. NXP also provides Binary blobs for all advanced IPs to enable a seamless experience for customers while porting and integrating their applications and offloading their workloads to these IPs. Additionally, NXP also supports FreeRTOS and a plethora of commercial RTOS from partners to address realtime customer applications enabling developers a quick and easy migration path.

Join fellow i.MX developers online at [community.nxp.com/](http://community.nxp.com/).

NXP also offers the [eIQ™ AI software development environment](#), a collection of libraries and development tools for building machine learning applications targeting i.MX applications processors and MCUs.

The eIQ toolkit leverages open-source technologies and is fully integrated into NXP's Yocto development environments, allowing the development of complete system level applications with ease.

## Hardware tools

The planned FRDM i.MX93W development board and supporting accessory boards enable SoC evaluation and rapid system prototyping, helping accelerate development and validation of a wide range of use cases.

## Compact package for simplified system design

The i.MX 93W will be available in a compact 14.2 × 12 mm package with 0.5 mm ball pitch, enabling simplified system integration and compact designs.

## Industrial qualified

The i.MX 93W applications processor will support the standard industrial temperature range (-40 °C to 105 °C Tj).

## Supply longevity

i.MX 93W will be part of [NXP's product longevity program](#) ensuring supply continuity and preserves your engineering investment for embedded designs for 15 years.

## i.MX 93W block diagram



## Single antenna block diagram

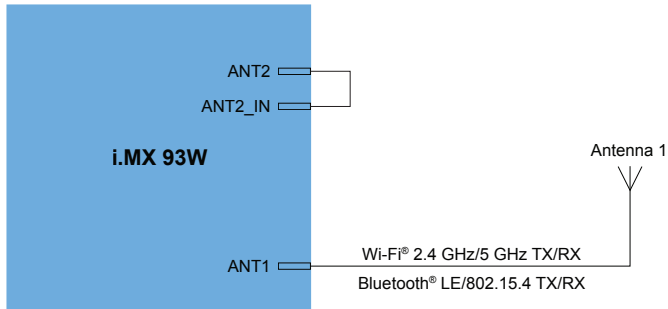

## Dual antenna block diagram

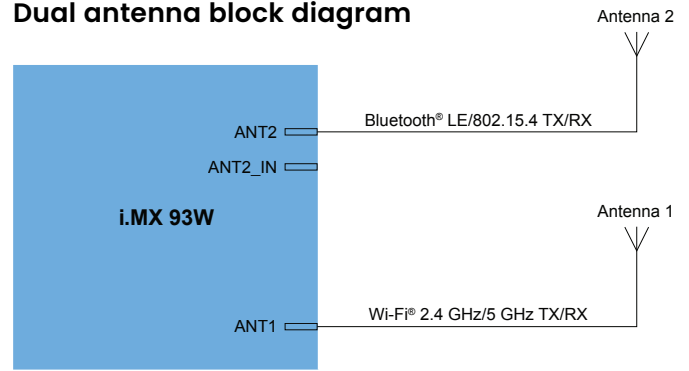

## Orderable part numbers

Product PN (A0)	# Cores (A55)	Qual tier	NPU	Speed	Package	Wireless	Family common features
MIMX93W52610GCMA	2	Industrial	Y	1.7 GHz	FCCSP402 14.2 mm x 12 mm, 0.5 Pitch		<b>Cortex-M33 @250 MHz</b>  <b>DDR</b> 3.7 GT/s x16 LPDDR4/4X  <b>Display</b> 1x 4-lane 1080p60 MIPI DSI 1x 4-lane LVDS 1x parallel display  <b>Camera</b> 1x 2-lane 1080p30 MIPI CSI 1x parallel camera  <b>Connectivity</b> 2x GbE (1w/TSN) 2x USB 2.0 2x CAN-FD  <b>Audio</b> 7x I <sup>2</sup> S TDM, SPDIF Tx+Rx, PDM, MQS
MIMX93W32610GCMA	2	Industrial	N	1.7 GHz	FCCSP402 14.2 mm x 12 mm, 0.5 Pitch	1x1 Dual-band (2.4 GHz / 5 GHz) Wi-Fi 6 + Bluetooth® LE/802.15.4	

[nxp.com/imx93w](http://nxp.com/imx93w)

NXP and the NXP logo are trademarks of NXP B.V. All other product or service names are the property of their respective owners. © 2026 NXP B.V.

Document Number: IMX937FS REV 1