

MCF5234 IEEE® 1588 Precision Time Protocol Solution

M5234BCCKIT-J

Overview

Freescale Semiconductor has aligned with National Semiconductor, IXAT Automation and CMX Systems to provide a comprehensive hardware and software solution to support the IEEE® 1588 Precision Time Protocol (PTP). The hardware components comprise a ColdFire microprocessor unit (MPU) and the new National Semiconductor DP83640 PHYTER®—an Ethernet PHY transceiver with PTP support. The software components include the IEEE 1588 software stack, supplied by IXAT and ported to the ColdFire MPU supporting the Precision Phyter, and the TCP/IP stack, supplied by CMX Systems. This solution can be combined with any ColdFire processor, but Freescale is currently offering the M5234BCCKIT-J, a cost-effective ColdFire MCF5234 evaluation system, which incorporates the DP83640 PHYTER allowing early development of an IEEE 1588 solution.

The MCF5234 is a member of a family of highly integrated, 32-bit microprocessors based on the V2 ColdFire core. The family features a 16- or 32-channel enhanced Time Processor Unit (eTPU) and a 10/100 Mbs Ethernet Controller on the popular Version 2 ColdFire core. This combination provides a cost-effective solution for networked control applications in the industrial automation segment that feature complex motor control.

MCF523x Family Features

- 8 KB I/D-Cache
- 64 KB SRAM
- Optional 10/100 Ethernet MAC (external PHY)
- 16- or 32-channel eTPU
- CAN 2.0B Controller (FlexCAN)
- Three UARTs
- Queued Serial Peripheral Interface (QSPI)
- I²C bus interface

MCF523x Family Block Diagram

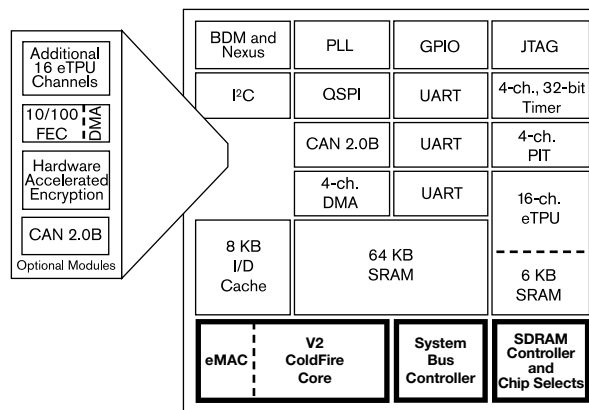

Freescal Technology

- 32-bit non-multiplexed data bus with eight chip selects
- 4-channel, 32-bit timers with DMA support
- 4-channel periodic interrupt timer
- 4-channel DMA controller
- SDRAM controller
- Up to 113 general-purpose input/outputs
- System integration (PLL, SW Watchdog)
- 1.5V core, 3.3V
- Optional hardware cryptography accelerator
- Industrial network switches, nodes or endpoints, which synchronize sensors and actuators over single wire distributed control networks
- Synchronizing power grid switches over large power networks
- Distributed test and measurement applications.

IEEE 1588 Precision Time Protocol Overview

The IEEE 1588 “Precision Clock Synchronization Protocol for Networked Measurement and Control Systems” (PTP) standard describes a method to quickly synchronize the clocks on multiple networked nodes to within tens of nanoseconds precision.

It is used in a wide range of target applications, including:

- Time-sensitive telecommunications—where precise time synchronization is required between communicating nodes

The standard allows distributed clocks to be rapidly aligned through the exchange of time-stamped messages. An IEEE 1588 enabled network configures and segments itself automatically, with each node using a Best Master Clock (BMC) algorithm to determine the node in each segment with the most accurate clock.

While the protocol can be realized in software only, with standard Ethernet components to provide precision levels of less than 100 micro-seconds, greater levels of accuracy require hardware support. By implementing hardware support on the M5234BCCKIT-J we allow time-stamping to occur as close to the physical layer as possible, greatly increasing the accuracy.

IEEE 1588 PTP Implementation on ColdFire MPUs

The MCF5234 ColdFire processor is optimized for performance in network-connected control applications where Ethernet is featured prominently. This, along with the PWM timers and serial communications for interface and control functionality, make this the ideal partner in this solution. Many of the time-sensitive options of the IEEE 1588 protocol have been implemented within the National Semiconductor DP83640, increasing the time stamp accuracy. The time-sensitive functionality includes a rate-controlled clock and timestamp hardware for both transmitted and received messages. The device also includes pins to provide input/output (I/O) control to allow triggering and monitoring of real-time events.

The DP83640 is connected to the ColdFire processor through a standard MII and Management Interface.

While the M5234BCCKIT-J specifically incorporates the National Semiconductor DP83640 PHYTER, the IEEE 1588 PTP capability can be easily supported on any Ethernet-enabled ColdFire device. The standard Ethernet controller used across the ColdFire family, combined with the National Semiconductor DP83640 PHYTER allows the IXXAT Automation IEEE 1588 stack and the CMX TCP/IP stack to be ported to any ColdFire device with minimal effort.

Development Tools, Software and Resources

Freescale Semiconductor has developed the M5234BCCKIT-J-based demonstration allowing customers to evaluate the ColdFire IEEE 1588 solution. The M5234BCCKIT-J provides a cost-effective evaluation board with 32 MB of SDRAM and 2 MB of external page mode flash. It also includes the P&E Multilink interface, allowing easy in-circuit debug. The latest version of the demo can be found via the M5234BCCKIT-J page on www.freescale.com.

ColdFire IEEE® 1588 Precision Time Protocol Solution Implementation

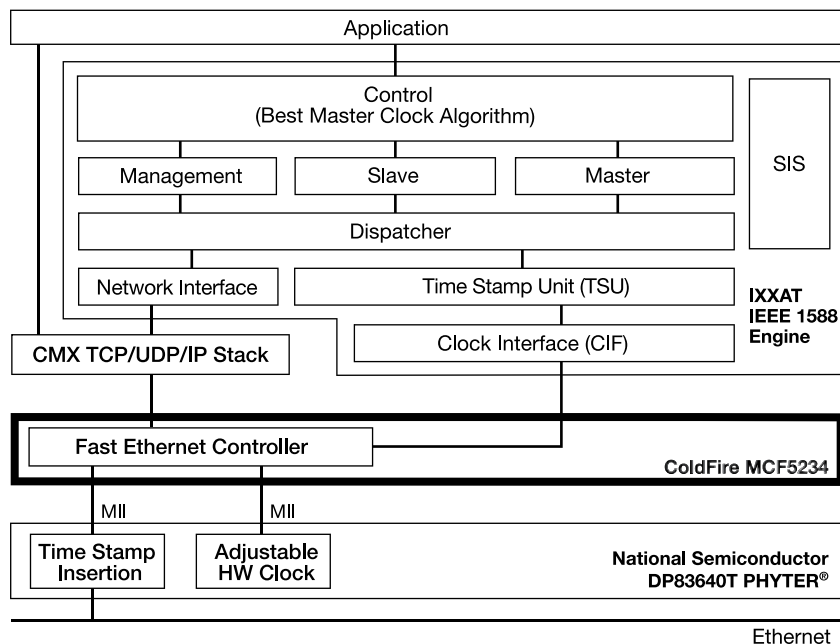

Freescal Technology

CodeWarrior Development Studio for ColdFire Architectures, V7.0—Complimentary*

CodeWarrior Development Studio for ColdFire architectures is a single tool suite that supports software development for Freescale's ColdFire family of 32-bit products. Support for all Freescale ColdFire devices coupled with the cross-platform capabilities of the award-winning CodeWarrior Integrated Development Environment (IDE) simplifies code migration and re-use for faster product development. Designers can further accelerate application development with the help of the Processor Expert rapid application development tool integrated into the CodeWarrior tool suite.

*Subject to license agreement

Where to Go for Additional Information

- Further IEEE 1588 solutions can be found at www.freescale.com/IEEE1588
- National Semiconductor www.ethernet.national.com
- IXXAT Automation www.ixxat.com
- CMX Systems www.cmx.com

M5234BCCKIT-J



Learn More:

For more information about the IEEE1588 solutions, please visit www.freescale.com/IEEE1588.