

**MOTOROLA
SEMICONDUCTOR
PRODUCT INFORMATION**

DSP56002EVM

Product Brief

24-Bit DSP56002 Evaluation Module

The DSP56002EVM Evaluation Module (EVM) is a low-cost platform designed to familiarize the user with Motorola's DSP56002 Digital Signal Processor (DSP). The 24-bit precision of the DSP combined with the on-board 32k words of external SRAM and stereo CD-quality audio codec makes the EVM ideal for implementing and demonstrating many audio processing algorithms as well as for learning the architecture and instruction set of the DSP56002 processor. The user need only supply a 7-9 volt calculator-style power supply and an RS-232 serial cable. Figure 1 illustrates the hardware.

The DSP56002EVM comes with Motorola's DSP56000 cross assembler and Domain Technologies' debug software with windowed user interface. The software runs under MS-DOS on an IBM PC-compatible computer (-386 class or higher) and communicates with the EVM over an RS-232 serial port.

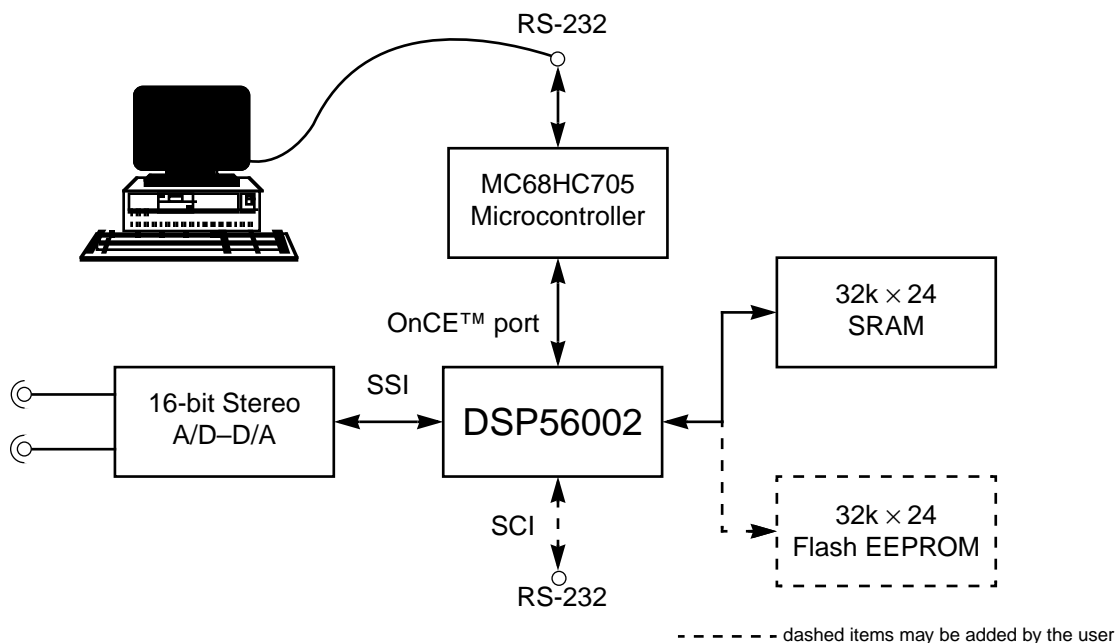

Figure 1 DSP56002EVM Block Diagram

Motorola reserves the right to change or discontinue this product without notice.



DSP56002EVM Features

Hardware

Fully assembled and tested printed circuit board containing:

- 24-bit DSP56002 Digital Signal Processor operating at 40 MHz
 - Up to 20 Million Instructions Per Second (MIPS) – 50 ns instruction cycle at 40 MHz
 - Up to 120 Million Operations Per Second (MOPS) at 40 MHz
 - Executes a 1024-point complex Fast Fourier Transform (FFT) in 59,898 clocks
 - Four 24-bit internal data buses and three 16-bit internal address buses for simultaneous accesses to one program and two data memories
 - 512 × 24-bit on-chip program RAM with bootstrap ROM
 - Two 256 × 24-bit on-chip data RAMs
 - Two 256 × 24-bit on-chip data ROMs containing sine, A-law and μ -law tables
 - External memory expansion with 16-bit address and 24-bit data buses
 - Byte-wide Host Interface (HI) with direct memory access support
 - Synchronous Serial Interface (SSI) to communicate with codecs and synchronous serial devices
 - Serial Communication Interface (SCI) for full-duplex asynchronous communications
 - 24-bit Timer/Event Counter also generates and measures digital waveforms
 - On-Chip Emulation (OnCE™) port for unobtrusive, processor speed-independent debugging
 - Software-programmable, Phase-Locked Loop-based (PLL) frequency synthesizer
- 32k × 24-bit zero-wait-state external Static RAM for expansion memory
 - Option for 32k × 8 bits of flash EEPROM for program bootstrapping and stand-alone operation
- Crystal Semiconductor's CS4215 stereo CD-quality sigma-delta Analog-to-Digital and Digital-to-Analog converter for high quality audio
 - 24.576 MHz crystal for audio sampling rates of 48, 32, 16, 9.6, or 8 kHz
 - 16-bit linear, 8-bit μ -law, 8-bit A-law, and 8-bit linear data formats
 - Option for other crystals/frequencies for other sample rates, such as 44.1 kHz
- MC7805ACT voltage regulator
- RS-232 interface to OnCE™ controller and Serial Communications Interface (SCI)
 - Option for a second RS-232 connector for access to the DSP56002 processor's serial communications port (SCI)
- MC68HC705K1 microcontroller performing RS-232-to-OnCE command conversion
- MC33078 pre-amp for analog buffering
- Strip connectors for external access to the DSP56002's memory expansion, host interface, and serial communications ports
- Jacks for stereo inputs, outputs, and headphones
- 2.1 mm jack and two screw terminals for power connection
- Documentation for the DSP56002, CS4215, assembler, and debugger, plus board schematics

Software

- Motorola's DSP5600x cross assembler
 - DSP56002 binary code from source code using labels, line numbers, definitions, and titles incorporating the architecture's complete instruction set and addressing modes, memory spaces, and parallel data transfers
 - Macros, expression evaluation, and functions for strings, data conversion, and transcendentals
 - Reports for cross-references, instruction cycle count, and memory use
 - Extensive error checking and reporting
- Domain Technologies' debug software with windowed user interface
 - Symbolic debugging
 - Four independent windows for data, disassembly, DSP registers, and commands
 - Data and registers displayed as fractions, decimals, or hexadecimal
 - Symbolic addressing and animated ASCII graphical display of memory segments
 - Up to 8 simultaneous breakpoints
 - Built-in assembler and disassembler
- Installation instructions and user notes on disk
- Demo software showing the advantages of 24 bits over 16 bits in audio processing
- Self-test files — executable and source code

Requirements

The user must provide the following:

- Power supply (7-9 V AC or DC, 700 mA)
- RS-232 cable with DB-9 connectors
- IBM PC-compatible computer (–386 class or higher) running MS-DOS with a serial port capable of operation at 19,200 baud

Options

The EVM easily accommodates the following user-additions:

- 32k × 8-bit flash EEPROM for program bootstrapping and stand-alone operation
- A second crystal for other sample rates, such as 44.1 kHz
- A second RS-232 connector to access the DSP56002's serial communications port (SCI)