



DSP56603

Product Preview 16-BIT DIGITAL SIGNAL PROCESSOR

The DSP56603 is a member of the DSP56600 core family of programmable CMOS Digital Signal Processors (DSPs). The DSP56600 core can execute one instruction per clock cycle. The 60 MHz chip includes a mixture of peripherals and large memories (3 K × 24 Program ROM, 16.5 K × 24 Program RAM, and 8 K × 16 X- and Y-data RAM each) optimized for processing-intensive, cost-effective, low power consumption digital mobile communications applications. A special Switch mode allows reconfiguration of on-chip memory. The DSP56600 core includes the Data Arithmetic Logic Unit (ALU), Address Generation Unit, Program Controller, Program Patch Detector, Bus Interface Unit, On-Chip Emulation (OnCE™)/JTAG port, and a Phase Lock Loop (PLL) based clock generator. The DSP56603 expansion area includes program and data memories, a triple timer module, an 8-bit Host Interface (HI08) port, and two 16-bit Synchronous Serial Interface (SSI) ports (see Figure 1). The DSP56603 also provides three to thirty-four GPIO lines, depending on which user-enabled peripherals are used, and four external dedicated interrupt lines. The DSP56603 is designed specifically for low-power digital handset wireless applications and can perform a wide variety of fixed-point digital signal processing algorithms. Because of its large RAM size, the DSP56603 supports rapid code development, shortening time to market. The ROM-based DSP56602 is the more cost-effective solution for mass production.

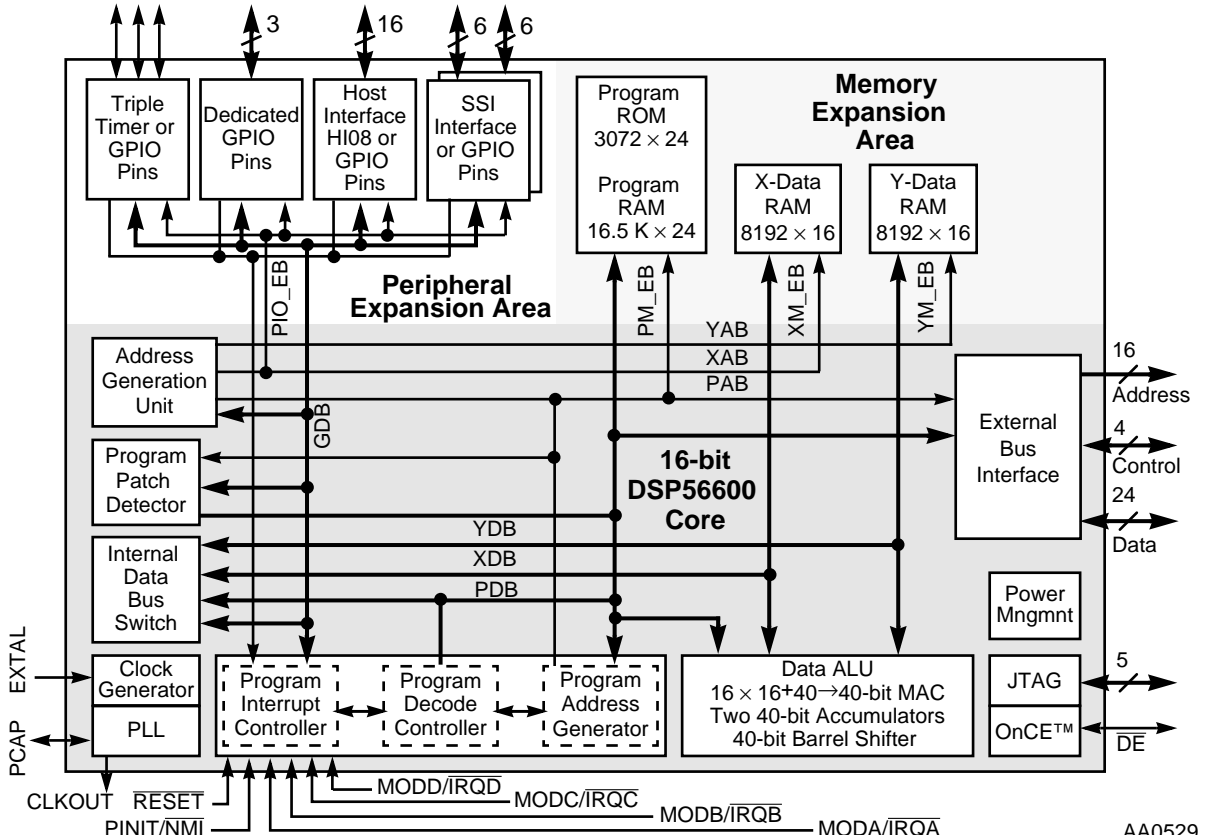

Figure 1 DSP56603 Block Diagram

This document contains information on a product under development. Motorola reserves the right to change or discontinue this product without notice.



Freescale Semiconductor, Inc.

FEATURES

- Digital Signal Processing Core
 - High-performance DSP56600 core
 - Up to 60 Million Instructions Per Second (MIPS) at 2.7 V–3.3 V
 - Fully pipelined 16 × 16-bit parallel multiply-accumulator
 - Two 40-bit accumulators, including extension bits
 - 40-bit parallel barrel shifter
 - Highly parallel instruction set with unique DSP addressing modes
 - Code-compatible with the DSP56300 core
 - Position-independent code support
 - Nested hardware DO loops
 - Fast auto-return interrupts
 - On-chip support for software patching and enhancements
 - On-chip PLL circuit
 - Real-time trace capability via external address bus
 - OnCE module and JTAG port
- Memory
 - Switch mode reconfigures program, X-data, and Y-data RAM sizes
 - Default configuration (Switch mode off)
 - 16.5 K × 24-bit Program RAM
 - 8 K × 16-bit X-data RAM
 - 8 K × 16-bit Y-data RAM
 - Switch mode on
 - 11.5 K × 24-bit Program RAM
 - 10.5 K × 16-bit X-data RAM
 - 10.5 K × 16-bit Y-data RAM
 - 3 K × 24-bit Program ROM
 - Off-chip expansion for both program fetch and program data transfers
 - Glueless interface to external SRAM

- Peripheral Circuits
 - Three dedicated General Purpose Input/Output (GPIO) pins and up to thirty-one additional GPIO pins (user-selectable as peripherals or GPIO pins)
 - Host Interface (HI08) support: One 8-bit parallel port (or up to sixteen additional GPIO pins)
 - Direct interface to Motorola HC11, Hitachi H8, 8051 family, Thomson P6 family
 - Minimal logic interface to standard ISA bus, Motorola 68K family, and Intel x86 microprocessor family
 - Synchronous Serial Interface (SSI) support: Two 6-pin ports (or twelve additional GPIO pins)
 - Supports serial devices with one or more industry-standard codecs, other DSPs, microprocessors, and Motorola-SPI-compliant peripherals
 - Independent transmitter and receiver sections and a common SSI clock generator
 - Network mode using frame sync and up to 32 time slots
 - 8-bit, 12-bit, and 16-bit data word lengths
 - Three programmable timers (or up to three additional GPIO pins)
 - Four external interrupt/mode control lines
 - One external reset pin for hardware reset
- Energy Efficient Design
 - Operating voltage range: 1.8 V to 3.3 V
 - Very low power CMOS design
 - < 0.85 mA/MIPS at 2.7 V
 - < 0.55 mA/MIPS at 1.8 V
 - Low power wait for Interrupt standby mode
 - Ultra low power Stop standby mode (< 50 μ A)
 - Fully static, HCMOS design for operating frequencies from 60 MHz down to DC
 - Special power management circuitry

PRODUCT DOCUMENTATION

The three manuals listed in **Table 1** are required for a complete description of the DSP56603 and are necessary to design properly with the part. Documentation is available from a local Motorola distributor, a Motorola semiconductor sales office, a Motorola Literature Distribution Center, or through the Motorola DSP home page on the Internet (the source for the latest information).

Table 1 Reference Documentation

Document Name	Description	Order Number
DSP56600 Family Manual	Detailed description of the DSP56600 family core architecture, 16-bit DSP core processor, and the instruction set	DSP56600FM/AD
DSP56603 User's Manual	Detailed description of memory, peripherals, and interfaces	DSP56603UM/AD
DSP56603 Data Sheet	Electrical and timing specifications, and pin and package descriptions	DSP56603/D

OnCE is a trademark of Motorola, Inc.
 Motorola, and  are registered trademarks of Motorola, Inc.



Motorola reserves the right to make changes without further notice to any products herein. Motorola makes no warranty, representation or guarantee regarding the suitability of its products for any particular purpose, nor does Motorola assume any liability arising out of the application or use of any product or circuit, and specifically disclaims any and all liability, including without limitation consequential or incidental damages. "Typical" parameters can and do vary in different applications. All operating parameters, including "Typical", must be validated for each customer application by customer's technical experts. Motorola does not convey any license under its patent rights nor the rights of others. Motorola products are not designed, intended, or authorized for use as components in systems intended for surgical implant into the body, or other applications intended to support or sustain life, or for any other application in which the failure of the Motorola product could create a situation where personal injury or death may occur. Should Buyer purchase or use Motorola products for any such unintended or unauthorized application, Buyer shall indemnify and hold Motorola and its officers, employees, subsidiaries, affiliates, and distributors harmless against all claims, costs, damages, and expenses, and reasonable attorney fees arising out of, directly or indirectly, any claim of personal injury or death associated with such unintended or unauthorized use, even if such claim alleges that Motorola was negligent regarding the design or manufacture of the part.

How to reach us:

USA/Europe:

Motorola Literature Distribution
 P.O. Box 20912
 Phoenix, Arizona 85036
 1 (800) 441-2447

MFAx:

RMFAx0@email.sps.mot.com
 TOUCHTONE (602) 244-6609

Hong Kong:

Motorola Semiconductors H.K. Ltd.
 8B Tai Ping Industrial Park
 51 Ting Kok Road
 Tai Po, N.T., Hong Kong
 852-2662928

Technical Resource Center:

1 (800) 521-6274

DSP Helpline:

dsphelp@dsp.sps.mot.com

Japan:

Nippon Motorola Ltd.
 Tatsumi-SPD-JLDC
 Toshikatsu Otsuki
 6F Seibu-Butsuryu-Center
 3-14-2 Tatsumi Koto-Ku
 Tokyo 135, Japan
 03-3521-8315

Internet:

<http://www.motorola-dsp.com>



**For More Information On This Product,
 Go to: www.freescale.com**