

**Product Brief**

**MOBILEGT™ TOTAL5200™  
STANDARD DEVELOPMENT  
PLATFORM FOR TELEMATICS,  
HANDS-FREE PHONES, AND  
DRIVER INFORMATION SYSTEMS**

**OVERVIEW**

The mobileGT Total5200™ Standard Development Platform (SDP) is designed for fast set-up and installation, allowing you to be productive in minutes. A fully integrated out-of-the-box development environment tightly integrates the QNX® Neutrino® RTOS, QNX Photon® microGUI, and QNX Momentics® IDE; IBM WebSphere® Device Developer Java IDE®, WebSphere® Micro Environment, and WebSphere® Custom Environment J9 Virtual Machine. Associated device-level drivers, libraries, system configurations, and sample applications have been written and optimized by Motorola, and technical support is available through Motorola.

**BENEFITS**

The mobileGT Total5200™ Standard Development Platform (SDP) offers the needed components to quickly develop scalable software solutions while saving valuable integration time and the associated costs, yet with more consistent quality. Re-use of common drivers and modules at lower levels allows common elements to be leveraged, saving both time and money. Developers may instead focus on value-added application and Human Machine Interface (HMI) developments to distinguish their end products.

**mobileGT DEVELOPMENT  
TEMPLATES**

This SDP is self-configurable to your development environment through the use of scripts and utilities. A fully networked image using NFS, CIFS, and TCP/IP is supplied to help you compile on your host and run on your target, all through an Ethernet connection—easy and fast! System configuration examples along with build files for hardware supported configurations are included.

**SYSTEM SUMMARY**

The SDP is a comprehensive automotive oriented solution for developers of rapid prototype and A-Sample telematics, driver information systems, camera-based event monitoring, navigation systems, automotive gateways, hands-free phone modules and other automotive-centric applications. It is based on the highly integrated, single-chip, low-power 760 MIPS MPC5200 processor containing a PowerPC® core. The 12VDC-powered system, with a DIN-sized main board offers comprehensive hardware utilities, such as a repositionable touchscreen graphics display, audio subsystem, automotive networking I/O, including CAN and Media Oriented Systems Transport (MOST)®. Connectivity to wireless subsystems such as cellular, Bluetooth™ modules, IEEE 802.11, and a rich set of varied I/O enable a wide variety of designs.



## Motorola Hardware and Firmware

### COMPREHENSIVE ON-CHIP I/O

- Multi-Serial (UART) for maximum design flexibility
- SPI (useful for Touchscreen, A/D Input, etc.)
- Dual USB Master 1.1 with OHCI support
- Dual CAN 2.0A/B (High Speed and Low Speed Fault Tolerant, Standard and Extended Frames, Programmable bit rate to 1Mbps)
- Ethernet 10/100 BaseT (7 Wire Industrial Standard Interface 10 BaseT implemented))
- Dual I<sup>2</sup>C (to 520Kbps) for thermometer, interchip and DSP communication, E2PROM, etc.
- Version 4 5V ATA (Compact Flash with True IDE mode)
- PCI Interface with PC104+ connector plus separate PCI clock drivers
- AC97 Audio Codec Interface
- Multiple, reconfigurable GPIO pins

### DEVELOPMENT SYSTEM EXPANSION I/O EXTENDS WITH THE FOLLOWING:

- Expansion for PCI, ATA/IDE, and Flash Card
- Expansion to 9 serial channels
- Expansion for extra GPIO lines
- MOST subsystem (asynchronous / synchronous in parallel combined mode) using Oasis OS8104AQR
- DSP co-processor interface
- Complete audio subsystem based on Crystal CS4299 CODECs
- Complete touchscreen graphics display support based on the Epson S1D13806; additional S-video, and CRT outputs



*mobileGT  
Total5200  
Target  
Hardware*

### SINGLE-CHIP, HIGHLY INTEGRATED 32-BIT PROCESSOR WITH FPU THAT IMPLEMENTS POWERPC ARCHITECTURE

- 400 MHz, one watt, cost-effective MPC5200 processor containing a PowerPC core
- 603e RISC Core with Floating Point Unit (FPU), crucial for GPS, Video Image Processing, Voice Recognition/Text-to-Speech, and other algorithm-intensive operations.
- 760 MIPS @ 400 MHz for plenty of application headroom
- Ethernet, Dual CAN, I<sup>2</sup>C, I<sup>2</sup>S, Serial, USB, SPI, AC97, COP/JTAG, J1850, PCI, ATA, and Double Data Rate (DDR) Memory Controller *on chip* for easy expansion. MOST, and audio subsystem off-chip
- On-Chip BestComm DMA I/O Control reduces CPU I/O management overhead
- -40 to +85C Automotive Qualified; QS9000 Certified helps to assure production quality and long-term availability

**For More Information On This Product,  
Go to: [www.freescale.com](http://www.freescale.com)**

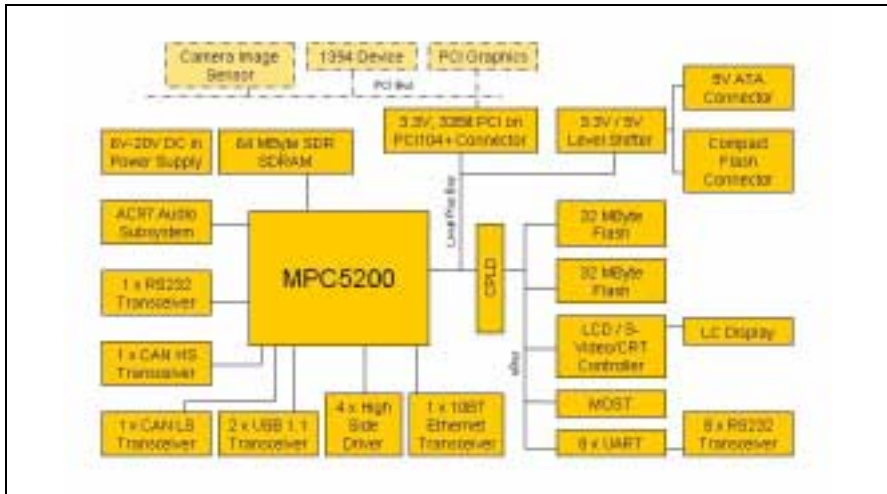

*mobileGT  
Total5200  
SDP  
Block  
Diagram*

**AUDIO SUBSYSTEM DAUGHTER CARD**

- Audio subsystem based on Crystal CS4299 CODECs
- Full connectivity to car radio
- Two microphone inputs, Bluetooth™ audio, stereo, radio, phone, MOST/Video, aux and line inputs
- 16-bit stereo speaker out
- Headphone out
- Amplifier
- On-board A/Ds

*Audio  
Subsystem  
Daughter  
Card  
Block  
Diagram*

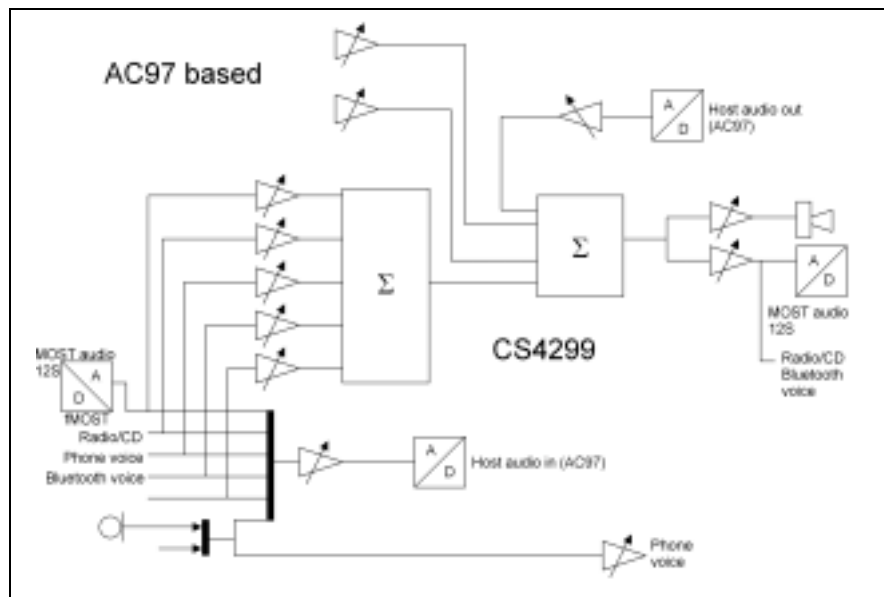

**QNX® MOMENTICS® IDE**

Enhance your productivity significantly with the QNX Momentics integrated development suite. Comprehensive, powerful, yet simple to use, QNX Momentics offers tightly integrated development tools for the SDP - all fueled by the QNX® Neutrino® realtime operating system (RTOS), which offers both reliability and scalability.

Built on the open, extensible Eclipse framework and integrated with the WebSphere Device Developer, the QNX Momentics integrated development environment (IDE) is designed to let you work with virtually any Eclipse tool. You can target the most popular development languages (C, C++, Embedded C++, Java) working in an integrated Windows® environment.

**QNX® NEUTRINO® RTOS AND QNX® PHOTON microGUI®**

The software foundation for the mobileGT platform, the QNX Neutrino RTOS combines a fault-tolerant architecture with a small memory footprint. Designed for dynamically upgradable driver information systems, the QNX Neutrino RTOS is designed to

allow new applications and drivers to be downloaded and started on the fly—no reboot or user intervention required. Automotive OEMs may, as a result, add new revenue-generating services to a system long after it's been installed in a vehicle. And QNX is POSIX compliant, enabling automotive OEMs and ISVs to leverage a large community of developers.

The core of the QNX Momentics IDE, QNX Neutrino is built on a microkernel architecture perfected from over 20 years of use in mission-critical environments. With this unique architecture, you get an extensible framework to create reliable, scalable, and high-performance products.

Engineered for POSIX compatibility, the QNX Neutrino OS offers a full-featured suite of components, including: distributed processing (Qnet™), resource managers, networking, graphical windowing system (QNX Photon microGUI®), Java®, file systems, BSPs, and drivers. The QNX Photon microGUI offers a customizable look-and-feel, full Unicode support, and a code-generating visual design tool—create complete interfaces without writing a line of code.

**JAVA® TECHNOLOGY FROM IBM PERVASIVE COMPUTING**

IBM's WebSphere Micro Environment includes the fully certified Java Powered J9 Virtual Machine (VM) and class libraries. The J9 VM is a highly configurable virtual machine, supporting multiple class libraries. WebSphere Custom Environment includes the J9 VM as well as specific configurations that can be optimized for the customer's specific driver information systems. Runtime RAM/ROM footprint can be optimized for size, startup speed, and runtime performance, with options for bytecodes, Just-In-Time (JIT) and Ahead-Of-Time (AOT) compilation for C-like performance.

J9 is highly optimized for the QNX RTOS at the thread level, providing optimal performance in embedded applications. J9 threading is highly optimized for the QNX RTOS, with extremely fast JNI calls for efficient access to your native libraries and legacy code.

The high-performance J9 garbage collector is accurate, incremental, and configurable. Lightweight embedded user interfaces include BMG and P3ML (based on XML), as well as AWT. The J9 VM is also engineered to support OSGi Bundle management for standardized dynamic downloads and hot code replacement.

The WebSphere Device Developer Java-powered IDE provides full tool support for the development, creation, and management of OSGi bundles in the IDE, as well as remote control of bundles on the target platform. Now you may build code once for virtually all target platforms, enhancing reliability, flexibility, and performance, while reducing testing, maintenance, and multiple platform configuration headaches.

**SPEECH, NOISE SUPPRESSION AND ACOUSTIC ECHO CANCELLATION (AEC) SOLUTIONS**

Several voice recognition, AEC, and noise suppression solutions are supported. The Fonix® Embedded Speech Solution Evaluation Kit offers a rapid speech development environment to generate speech applications directly on the SDP. This provides an efficient means to develop production-ready, voice-enabled applications. IBM Embedded ViaVoice™ gives mobileGT applications the capacity for an unlimited embedded vocabulary. This enables access to voice-enabled databases with millions of records and is integrated with the J9 VM. The ScanSoft® VoCon® 3200 Embedded Development System is a complete development suite to add speech recognition functionalities on the mobileGT SDP to automotive and other embedded applications like voice destination entry for navigation or voice activated dialing. Clarity's award-winning CVC®-Clear Voice Capture echo and noise suppression solutions dramatically improve the quality and accuracy of voice-based interfaces. ClearStream™ and other speech enhancement solutions for mobileGT is provided by Wavemakers® and will be in production systems in 2004.

**For More Information On This Product,  
Go to: [www.freescale.com](http://www.freescale.com)**

## CONNECTORS

NAME	DESCRIPTION	PHYSICAL CONNECTOR
JTAG Programming	Classic interface for Xilinx JTAG	10 pin PCB header
COP	Standard COP (Lauterbach or Abatron interface)	8 x 2 pin PCB header
MOST	Media Oriented Systems Transport	Bigfoot connector, 2-way
USB (x2)	Universal Serial Bus (x2)	Dual USB connector
CAN (HS)	High Speed Controller Area Network (CAN)	10-pin PCB header
CAN (LS)	Low speed fault tolerant CAN	10-pin PCB header
Wakeup	Wakeup from Sleep Mode	Minifix connector (5x2)
GPIO	8 bits of General Purpose I/O	Minifix connector (5x2)
Timer	Timers/Input catch/Output compare/PWM	Minifix connector (5x2)
Touch screen	4-wire resistive touch screen input	5 pin PCB header
LCD Power	5V power for TFT-LCD twin backlights	5 pin PCB header
SPI	Serial Peripheral Interface	4 pin PCB header
LCD	Thin-film-transistor Liquid Crystal Display	32 pin Hiroshi connector
LCD GPIO	General Purpose I/O on Epson LCD controller	10-pin PCB header
UART0	Serial Port that supports HW Flow control	DB9, male
UART1	Serial Port with complete MODEM signals	Minifix connector (5x2)
UART 2+3	Serial Ports (2) that support SW Flow control	Minifix connector (5x2)
UART 4	Serial Port that supports HW Flow control	Minifix connector (5x2)
UART 5+6	Serial Ports (2) that support SW Flow control	Minifix connector (5x2)
UART 7+8	Serial Ports (2) that support SW Flow control	Minifix connector (5x2)
Button Interface	Panel Button Interface control	Minifix connector (5x2)
Ethernet	10 Base-T Ethernet	10-pin RJ-45 jack
Compact Flash	External Flash memory card	50 pin Compact Flash slot
ATA	Ultra ATA 100 (Ultra Direct Memory Access)	40 pin ATA slot
PC104	Slots for stackable PC-104 sized card	4 x 30 (120) slot connector
Bluetooth™ audio	Audio output for Bluetooth™ wireless technology	Stereo Jack – 2.5mm
Phone	Audio I/O for telephone	Stereo Jack – 2.5mm
AUX IN	Audio input from auxiliary source	Stereo Jack – 3.5mm
MOST/Video	Audio output to MOST system	Stereo Jack – 3.5mm
Radio IN	Audio input from radio source	RCA Jacks (left and right)
Mono-Microphone 1	Audio input from microphone with amplifier	Stereo Jack – 3.5mm
Mono-Microphone 2	Audio input from microphone	Stereo Jack – 3.5mm
Line-level IN	Line-level input (2 channels)	Stereo Jack – 3.5mm
Headphone	Audio output to headphones	Stereo Jack – 3.5mm
Speaker OUT	Audio output to external speakers	RCA Jacks (left and right)
S-Video	S-Video standard video output	S-Video Mini DIN connector
VGA	Video Graphics Adapter output	15-pin VGA connector

### Front Panel Connections



For More Information On This Product,  
Go to: [www.freescale.com](http://www.freescale.com)

## MEMORY

- 64 Mbytes SDRAM. Processor can also support DDR memory and larger sizes
- 64 Mbytes Flash organized as 2 x 32 bit-wide banks

## ON-BOARD POWER MANAGEMENT

- Support of MPC5200 Sleep (real-time clock only) modes
- Sequenced power on (1.5, 2.5, 3.3 then 5V sequence)
- SDRAM self refresh
- Selective transceiver shutdown
- DC/DC converters stay on with minimal load
- ATA level shifters enabled only by ATA chip select

## mobileGT SDP CONTENTS

- mobileGT Total5200 Standard Development Platform CD from Motorola
- QNX Momentics Professional Edition Evaluation CD
- IBM Websphere Studio Device Developer SDK
- Motorola DIN1 form-factor hardware system with integrated graphics display and power supply
- Documentation and start-up support

## TECHNICAL SUPPORT

Various standard training courses are available. Annual technical support contracts are available to help keep projects on track. For further product development, support contracts can be customized to meet specific training, consulting, or custom engineering needs.

mobileGT Total5200 SDP with 30-Day Evaluation License of QNX  
Part # MPCSYS5200EVAL

Description: The mobileGT Total5200 SDP with 30-Day Evaluation License of QNX includes the Total5200 hardware and all software for a complete development environment. The SDP includes a QNX SDK and the Momentics IDE for developing software applications. The mobileGT SDP CD contains a 30-day Evaluation License of QNX.

Price: \$5,000 each

- Access for additional MPC5200 Information:  
<http://e-www.motorola.com> or <http://www.mobilegt.com/>
- Access for additional QNX Information: <http://www.qnx.com/>
- Access for IBM WebSphere Device Developer Java IDE and the J9 Virtual Machine Information: <http://www-3.ibm.com/software/wireless/wsdd/>

Additional documentation:

- 760 MIPS MPC5200 Lite5200™ EVB: MPC5200LITEPB/D
- MPC5200 Technical Summary: MPC5200TS/D

Motorola SPS General Customer Technical Call Center: 1 (800) 521-6274

## COLOR GRAPHICS DISPLAY

- 16-bit TGT LCD controller (640 x 800, 64K colors) based on the Epson S1D13806
- 6.5 in. TFT color LCD display; 640 x 480 pixels; 262,144 colors
- 16 general purpose buttons; two general purpose rotary-push knobs; five navigation buttons
- Resistive touch screen

## DIMENSIONS

- Board enclosure: 186mm x 180mm x 84mm
- Main board: 172mm (width) x 165mm (depth), excluding connectors
- Audio subsystem board: 172mm (width) x 60mm (depth), excluding connectors
- Power subsystem board: 172mm (width) x 60mm (depth)
- Touchscreen graphics display head: 213mm x 175mm x 57mm

## POWER REQUIREMENTS

- Single 12VDC @ 2A direct automotive connection (will accommodate 6-20V). International 110-250 VAC (50-60 Hz) Power Adapter included
- All required voltages derived from single source
- 2.5 A fuse
- 1.5V, 2.5V, 3.3V, and 5V rails may be introduced separately, if desired

Information in this document is provided solely to enable system and software implementers to use Motorola products. There are no express or implied copyright licenses granted hereunder to design or fabricate any integrated circuits or integrated circuits based on the information in this document. Motorola reserves the right to make changes without further notice to any products herein. Motorola makes no warranty, representation or guarantee regarding the suitability of its products for any particular purpose, nor does Motorola assume any liability arising out of the application or use of any product or circuit, and specifically disclaims any and all liability, including without limitation consequential or incidental damages. "Typical" parameters that may be provided in Motorola data sheets and/or specifications can and do vary in different applications and actual performance may vary over time. All operating parameters, including "Typicals" must be validated for each customer application by customer's technical experts. Motorola does not convey any license under its patent rights nor the rights of others. Motorola products are not designed, intended, or authorized for use as components in systems intended for surgical implant into the body, or other applications intended to support or sustain life, or for any other application in which the failure of the Motorola product could create a situation where personal injury or death may occur. Should Buyer purchase or use Motorola products for any such unintended or unauthorized application, Buyer shall indemnify and hold Motorola and its officers, employees, subsidiaries, affiliates, and distributors harmless against all claims, costs, damages, and expenses, and reasonable attorney fees arising out of, directly or indirectly, any claim of personal injury or death associated with such unintended or unauthorized use, even if such claim alleges that Motorola was negligent regarding the design or manufacture of the part.



MOTOROLA and the Stylized M Logo are registered in the US Patent and Trademark Office. All other product or service names are the property of their respective owners. The "PowerPC" name is a trademark of IBM Corp. and used under license from IBM Corp. The Bluetooth trademarks are owned by their proprietor and used by Motorola, Inc. under license. Java and all other Java-based marks are trademarks or registered trademarks of Sun Microsystems, Inc. in the U.S. and other countries. © Motorola Inc. 2004

MOBILEGT5200PB/D  
Rev. 3  
03/2004

**For More Information On This Product,  
Go to: [www.freescale.com](http://www.freescale.com)**