

DRM for Driver Information System on S12G128

Reference Design

Document Number: DRM134
Rev. 0, 04/2012

Contents

Section Number	Title	Page
Chapter 1		
Introduction		
1.1	Introduction.....	5
1.2	Key Features of DIS Voice Module.....	5
1.2.1	Future Enhancement.....	6
Chapter 2		
Application Block Diagram		
2.1	Application Block Diagram.....	7
2.1.1	Main Blocks.....	7
2.1.2	Functionality.....	8
2.2	Module Explanation.....	9
2.2.1	MCU – MC9S12G.....	9
2.2.2	MSDI – MC33972.....	10
2.2.3	Audio Amplifier - TDA7350A.....	10
2.2.4	Relay Switches.....	10
2.2.5	Intelligent Power Control.....	11
2.3	Hardware Board.....	12
Chapter 3		
Software		
3.1	Audio Generation Technique.....	13
3.2	Software Design.....	13
3.2.1	Design Flow.....	13
3.2.2	Function Description.....	14
3.2.2.1	Configure_Output_Compare.....	15
3.2.2.2	SPI_Init.....	15
3.2.2.3	MC33972_Config.....	15
3.2.2.4	SwitchRelay.....	15
3.2.2.5	Check_MSDI_Inputs.....	16

Section Number	Title	Page
3.2.2.6	Decode_Message.....	16
3.2.2.7	Timer_ISR.....	16

Chapter 1

Introduction

1.1 Introduction

New technologies in four wheelers that make them faster and safer have made their interaction with the driver important. Driver Information System (DIS) includes the instrument cluster located in front of the driver on dashboard which displays various information like speed of vehicle, distance travelled, fuel level, ambient temperature and others. Instrument cluster is gaining in sophistication with every passing day. Apart from the standard analog gauges (like odometer or speedometer), graphics LCD (or TFT) displays for infotainment, LED warning lights, audio warning messages, lane departure sensor, distance alert sensor and others provide the real time crucial information to the driver.

The DIS described in this application is a module integrated with the car stereo system that generates audio messages when warnings like door is open, seatbelt is unlocked, initiates if the car ignition is ON. When car ignition is turned OFF, the DIS module turns ON the headlights for 45 sec. to assist the driver to walk on the pathway after he parks the vehicle. This 45 sec. time is programmable.

This document describes the hardware design and the software implementation for the DIS application.

1.2 Key Features of DIS Voice Module

The key features of DIS voice module are listed below:

- Messages comprise of 8-bit audio samples of sampling frequency 11 kHz.
- A switch is provided to disable the currently playing warning message until the next ignition.

- Messages are played on priority basis i.e. if multiple warning signals occur at the same time then the message with highest priority is played.
- Headlights will be turned ON for 45 sec. after the ignition is turned OFF.

1.2.1 Future Enhancement

User can customize voice messages by deleting or loading audio samples on the flash memory using SPI.

Chapter 2

Application Block Diagram

2.1 Application Block Diagram

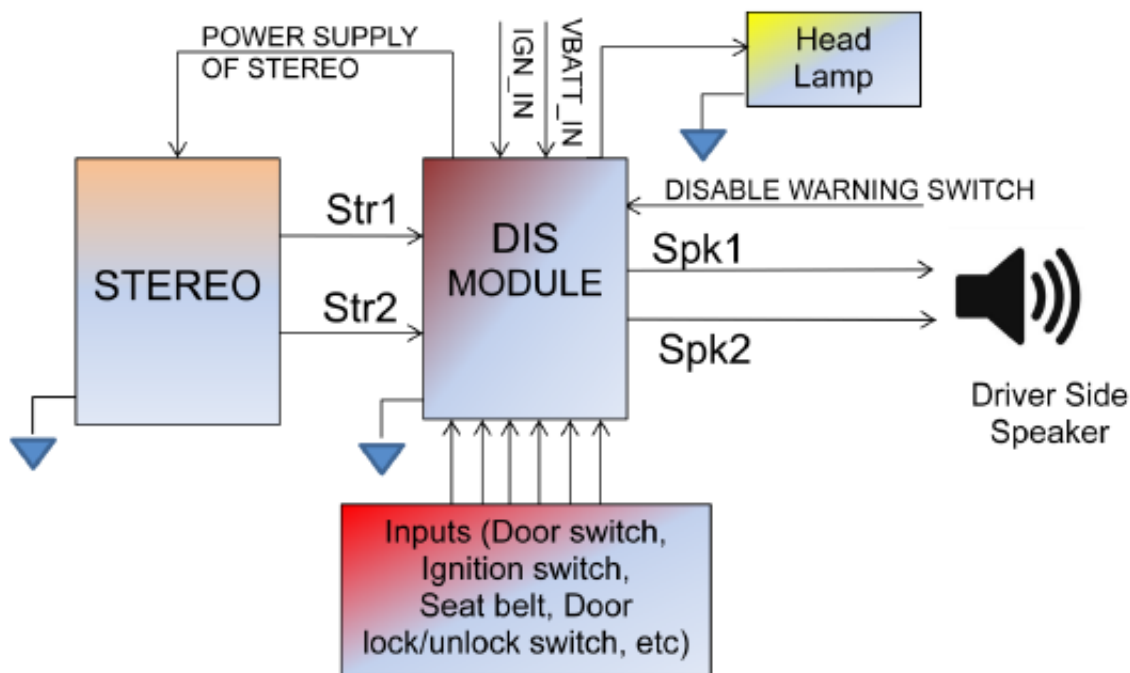

VBATT_IN is input voltage from car battery to DIS Module
IGN_IN is ignition signal as input to DIS module

Figure 2-1. Block Diagram of complete DIS

This block diagram explains the integration of DIS module with the car stereo system. The DIS is incorporated between stereo and driver side speaker.

2.1.1 Main Blocks

The main blocks of Fig 2-1 are as follows:

- DIS Module – It generates the voice messages based on the input warning signals.

- Stereo – It is the car’s in-built stereo system.
- All digital warning inputs – On the basis of these input signals, DIS module selects the voice message that needs to be played.
- Headlamp – It refers to headlights of the car.
- Driver side speaker – These are the speakers present in the casing of the dashboard.

2.1.2 Functionality

As soon as ignition is switched ON, DIS module is powered up and user specific welcome message is played. With any of following conditions, user specific warning message is played:

- Front right door is open
- Front left door is open
- Rear right door is open
- Rear left door is open
- Hood is open
- Seatbelt not fastened
- Cabin light is ON
- Door is unlocked

These warning messages are played until an action is taken for the corresponding warning. The message is played through same speaker (driver side) as used with stereo system. Hence, during message output, stereo is switched OFF and speaker inputs are switched from stereo to DIS module. If the ‘Disable Warning’ switch is pressed, while a message is being played then that message will not be played until next ignition. When ignition is turned OFF, headlamp is turned ON for 45 sec.

The DIS module consists of the following sub-modules:

- MCU MC9S12G - It is the heart of the system and is responsible for complete functionality of DIS module.
- Multiple Switch Detection Interface (MSDI) - It is used to detect the occurrence of warning signals and to communicate this occurrence to MCU using SPI bus.
- Relay Control – It is used to switch ON/OFF headlamp & stereo and to switch the speaker input between stereo and DIS module.
- Serial Flash – It is SPI based serial flash memory which will be used for future voice message extension.
- Intelligent Power Control Module – It controls the power supply to MCU and keeps the MCU ON after the ignition is turned OFF.

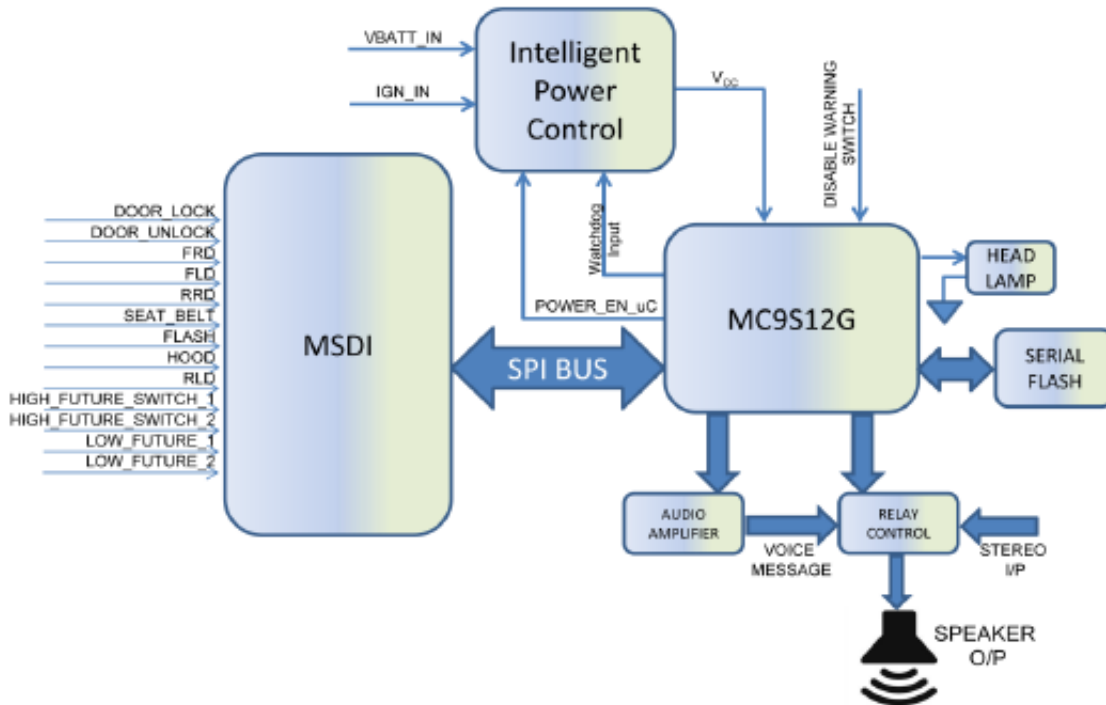

VBATT_IN is input voltage from car battery to DIS Module

IGN_IN is ignition signal as input to DIS module

POWER_EN_uC is active high signal from MCU that (along with VBATT_IN) drives Intelligent Power Control Module when IGN_IN signal is off

Figure 2-2. Internal Block Diagram of DIS Module

2.2 Module Explanation

2.2.1 MCU – MC9S12G

- In DIS module, 48-Pin LQFP (Low-profile Quad Flat Package) of MC9S12G128 microcontroller is used which has 128KB of flash and 8KB of RAM. MC9S12G family is pin compliant from low end (MC9S12G16) to high end (MC9S12G240), so we can use any S12G 48-pin MCU as per the number of messages.
- The MC9S12G family is an optimized, automotive, 16-bit microcontroller product line focused on low-cost, high-performance, low power consumption, low pin-count and code-size efficiency.
- The following modules of MCU are used in this application:
 - Serial Peripheral Interface (SPI) – used for communication with MSDI switch
 - Timer Module – used for generating periodic interrupts

- Pulse Width Modulator (PWM) – used for generating audio waves
- I/O Ports – used for various input & output signals like ignition, ‘Disable Warning’ switch and others.

2.2.2 MSDI – MC33972

- MC33972 MSDI is designed to detect the closing and opening of up to 22 switch contacts.
- The switch status, either open or closed, is transferred to the MCU through a SPI.
- The MC33972 device has two modes of operation, Normal and Sleep.
- In this application, we are using Normal mode which allows programming of the device and configuration of switch contacts as pull-up or pull-down.
- Advantages of using a MSDI:
 - Component Optimization: MSDI replaces discrete components such as transistors, resistors and diodes in the existing circuit. Integrated system also increases reliability of the entire system.
 - PCB space Optimization: Since the above mentioned discrete components are replaced by a single 32-pin SOIC package, the PCB space requirement is drastically reduced.
 - Reduction in MCU I/O pin count: MSDI connects to MCU through SPI whereas discrete switches connect to MCU pins as GPIO or KBI. Hence requirement of MCU pins is greatly reduced.
 - Improved yield in production line: Reduction in number of components leads to reduction in the number of solder joints, the time required for assembling the PCBs and also the time required for visual inspection.

2.2.3 Audio Amplifier - TDA7350A

The TDA7350A is a class AB audio power amplifier used for audio amplification and noise reduction in our design.

2.2.4 Relay Switches

Two types of relay switches are used in DIS application:

- Omron G5V-2 DPDT relay: used to switch the speaker inputs from stereo signals to voice message signals (from DIS) and vice-versa.
- NEC EX2 DPDT relay: used to switch ON/OFF the stereo signal and switch ON/OFF the headlamp signal.

2.2.5 Intelligent Power Control

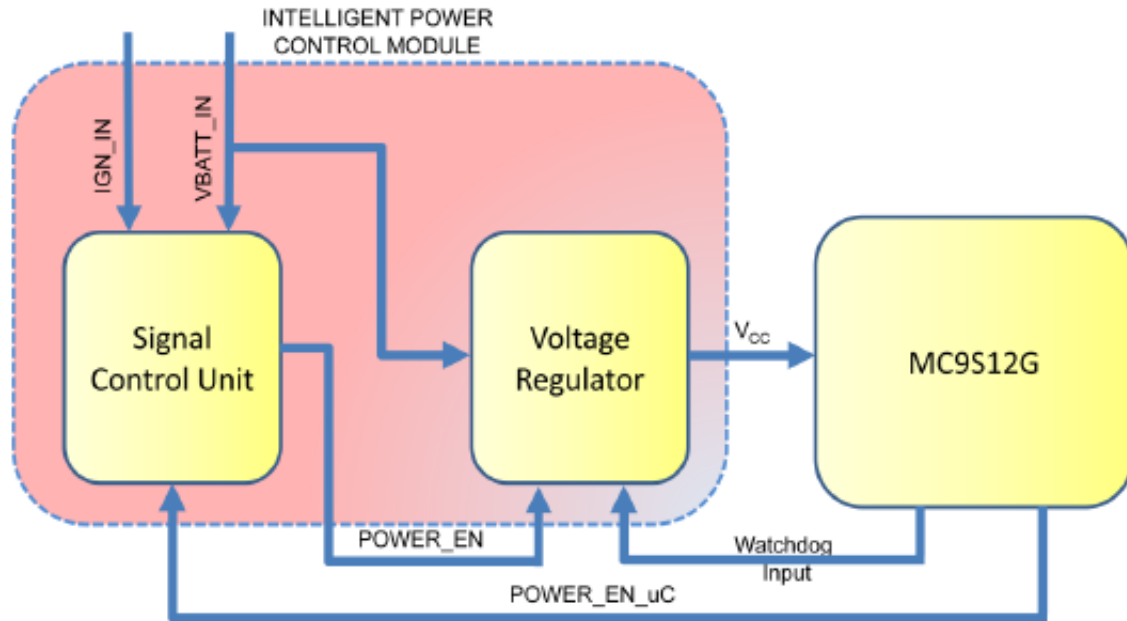

VBATT_IN is input voltage from car battery to DIS Module
IGN_IN is ignition signal as input to DIS module
POWER_EN_uC is active high signal from MCU that (along with VBATT_IN) drives Intelligent Power Control Module when IGN_IN signal is off
POWER_EN signal enables the voltage regulator

Figure 2-3. Block Diagram of Intelligent Power Control module

It is a feature of the DIS that headlamp is kept ON after ignition is turned OFF. For this purpose, the power control module on DIS is made in such a way that it can keep the board powered up using battery voltage even after ignition is switched OFF. The module consists of two blocks:

- Signal Control Unit: transistor circuit that enables or disables the voltage regulator
- Voltage Regulator (L4979): converts the unregulated 12V input (from battery) to regulated 5V output

When the ignition is switched ON, the signal control unit sends POWER_EN signal (generated from IGN_IN signal) to the voltage regulator. This enables the regulator and generates regulated V_{cc} from VBATT_IN. MCU gets powered up and it sends Watchdog Input in form of square wave to the regulator that prevents it from resetting. The MCU also sends active high POWER_EN_uC signal to the signal control unit, which causes POWER_EN to come from VBATT_IN signal. Till the time POWER_EN_uC line is high, VBATT_IN keeps the regulator enabled. Hence, when the ignition is turned OFF,

the voltage regulator remains enabled and thus MCU remains powered up. The MCU now switches ON the headlamp relay for 45 sec. After that, the MCU will make POWER_EN_uC signal low that disables POWER_EN signal and in turn the voltage regulator gets switched OFF and hence power to MCU as well as board goes OFF. The board will perform the same cycle on next ignition.

2.3 Hardware Board

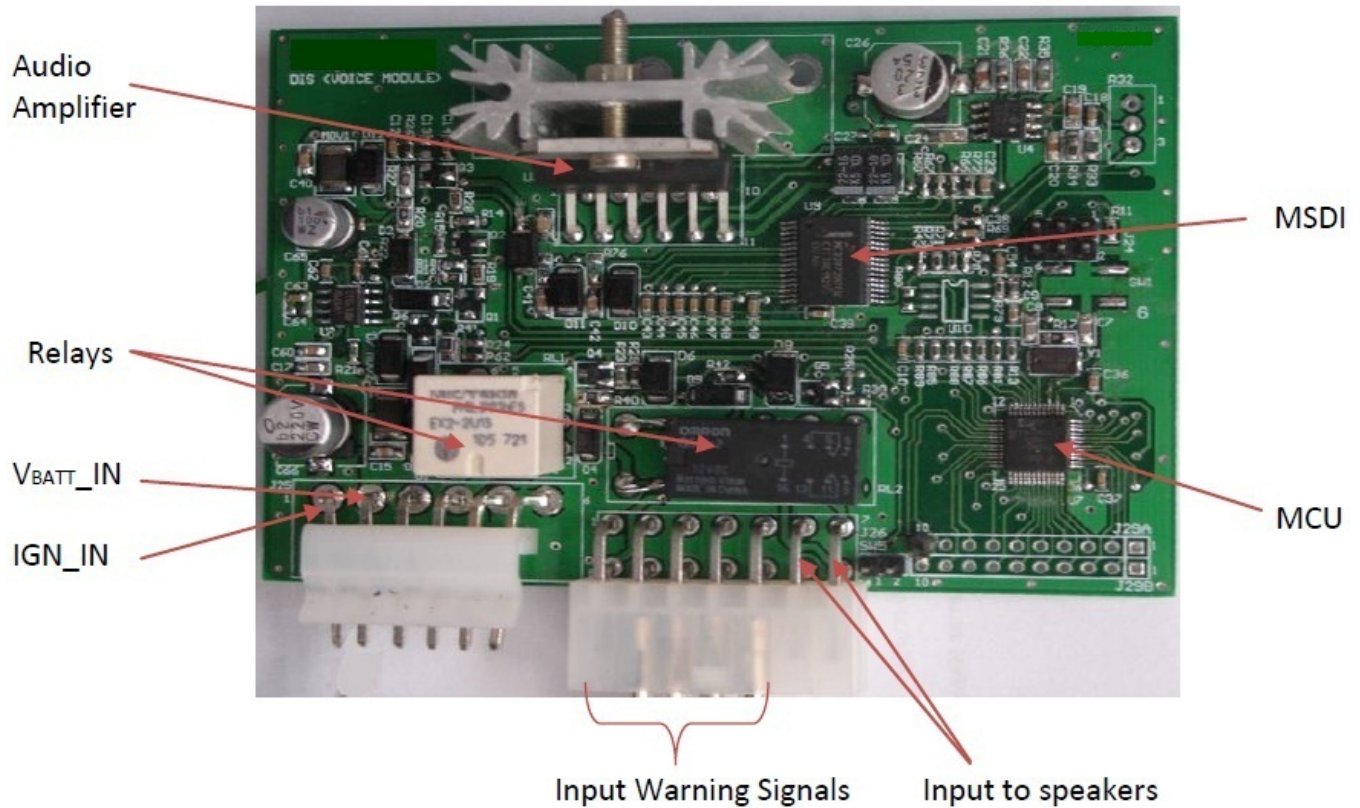

Figure 2-4. Components mounted DIS hardware board

Chapter 3 Software

3.1 Audio Generation Technique

In this application, audio generation is done by PWM signals, generated using PWM module (IP S12PWM8B8CV2) of the MCU. The basic principle involves using sampled data to vary the duty cycle of a PWM signal. The duty cycle values are updated at intervals specified by a timer. The signal produced by the PWM module is then fed to a low-pass filter, which effectively integrates the pulsed data and produces a signal that is decipherable by the human ear.

The voice messages are .wav files which are converted into ASCII format and stored in flash memory in the form of arrays. The array elements serve as the duty cycle values of the PWM signal. When the MSDI communicates the warning signal to the MCU, the corresponding array is selected for generating PWM signal. The timer module is configured in 'output compare mode' with the compare value as $1/f$ (f is the sampling frequency of the .wav file). At every 'output compare' interrupt, the duty cycle register of PWM is updated with array elements of corresponding .wav file.

3.2 Software Design

3.2.1 Design Flow

1. When the MCU is powered up, pulsed output is given from the MCU to the Watchdog Input pin of voltage regulator to prevent it from resetting.
2. The welcome message is played.
3. The status of switches on MSDI is checked using SPI Bus.
4. If any switch is closed, then the relays are switched ON to stop stereo and change the speaker inputs from stereo to voice module.
5. The message is played accordingly and till the time the corresponding switch on MSDI is closed, the message is played with an interval of 5 seconds.

6. If the 'Disable Warning' switch is pressed then the current message is stopped and its input signal is masked from the switch on MSDI until the next ignition.
7. If multiple switches on MSDI are closed at the same time, then the message will be played with input having highest priority.

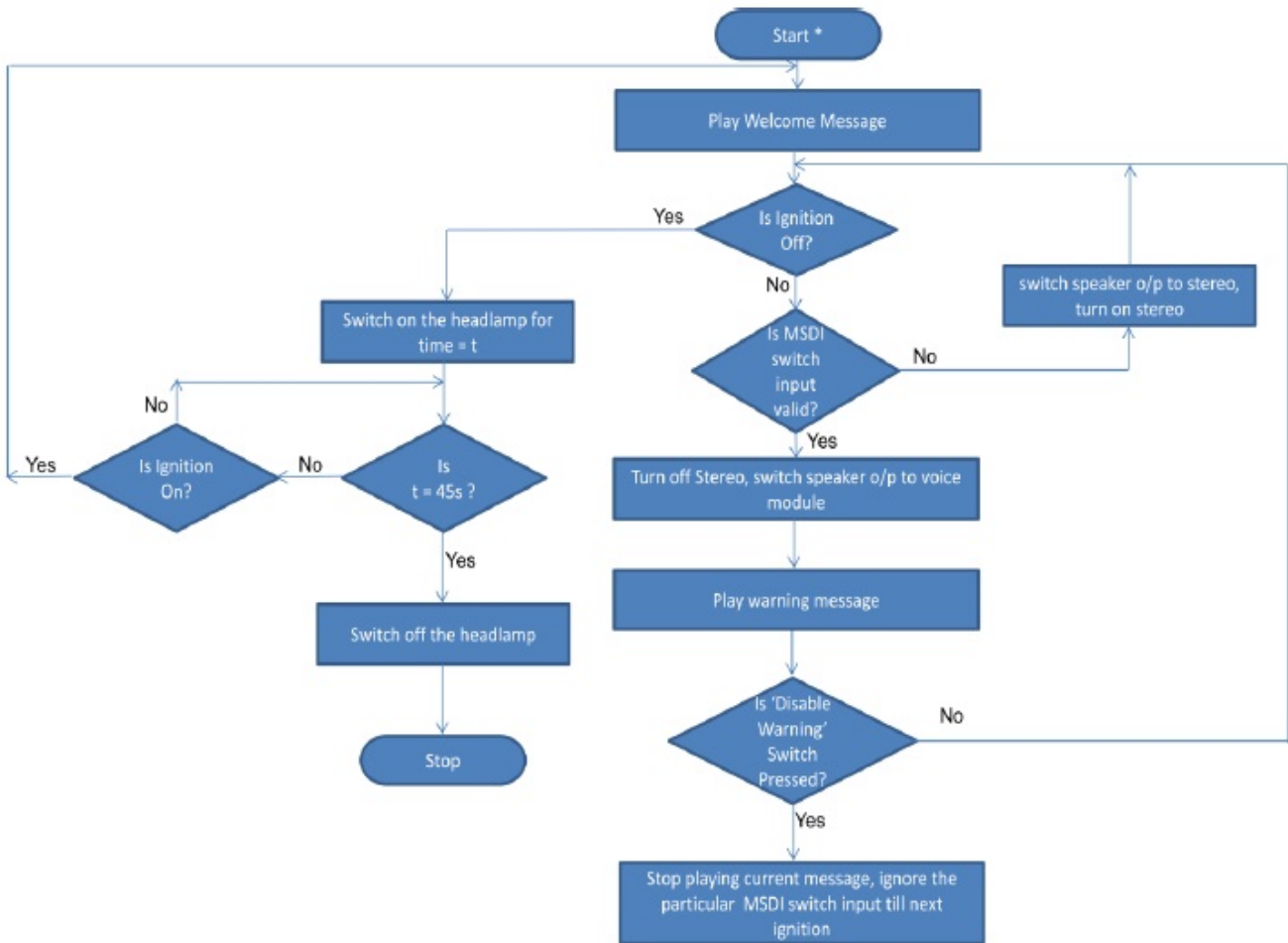

* Start means ignition is on

Figure 3-1. Software Flow Diagram

8. If no switch on MSDI is closed, then relays are switched OFF to move speaker inputs from voice module to stereo and switch ON the stereo.
9. Till the time ignition is ON, steps 2 to 7 are repeated continuously.
10. If ignition is turned OFF then headlamp is switched ON by switching its relay ON and the regulator enable bit is kept high for 45 seconds. If the ignition is turned ON during this time then step 2 onwards are performed.
11. Then, headlamp relay is switched OFF and enable pin of regulator is made low to switch OFF the voltage regulator output.

3.2.2 Function Description

3.2.2.1 Configure_Output_Compare

This function is used to configure the timer channel in Output Compare mode.

Syntax
void Configure_Output_Compare (void)
Arguments
None
Return Type
None

3.2.2.2 SPI_Init

This function initializes the specified SPI by writing the internal registers which configure the data transfer width, Clock frequency of SPI, mode of operation of MCU and Chip Select pin of the SPI.

Syntax
void SPI_Init (void)
Arguments
None
Return Type
None

3.2.2.3 MC33972_Config

This function is used to configure the MSDI - MC33972. As the supply for MC33972 is provided using Ignition signal, hence this function is called every time the ignition is turned ON. This configuration is done by sending SPI commands from the MCU to the MSDI Switch.

Syntax
void MC33972_Config (void)
Arguments
None
Return Type
None

3.2.2.4 SwitchRelay

This function is used to switch ON/OFF the relays for stereo, headlamp and speaker input selection.

Syntax
void SwitchRelay (int device, int state)
Arguments
device: It is an int type variable which is used to specify the device whose state needs to be changed by switching of relay.
state: It is an int type variable which is used to specify the state ON/OFF in which the

device needs to be switched to.

Return Type

None

3.2.2.5 Check_MSDI_Inputs

This function is used to check the input switch nodes on MSDI. If any switch is closed, then the corresponding message is selected for playing. The selection is done on the basis of priorities i.e. if multiple switches on MSDI are closed at the same time, then the message corresponding to highest priority input is selected for playing.

Syntax

void Check_MSDI_Inputs (void)

Arguments

None

Return Type

None

3.2.2.6 Decode_Message

This function decodes which switch on MSDI is closed. This occurs when a warning message needs to be played on the DIS. In case, the ‘Disable Warning’ switch is pressed while a switch on MSDI is closed, then that warning message is not played till next ignition is received.

Syntax

UINT32 Decode_Message (void)

Arguments

None

Return Type

The return type is unsigned long int (UINT32). It tells which switch input on MSDI has a valid input at the time of pressing the reset switch.

3.2.2.7 Timer_ISR

This Interrupt Service Routine (ISR) is executed when there is match of timer counter with timer channel 7 output compare value. The frequency of this match is the sampling frequency of the audio samples (in this application, it is 11 kHz). When a message is played, PWM duty cycle values are assigned in this ISR function. The Watchdog Input pin is also toggled in this ISR.

Syntax

void interrupt < interrupt vector number> Timer_ISR (void)

Arguments

None

Return Type

None

How to Reach Us:

Home Page:

www.freescale.com

Web Support:

<http://www.freescale.com/support>

USA/Europe or Locations Not Listed:

Freescale Semiconductor
Technical Information Center, EL516
2100 East Elliot Road
Tempe, Arizona 85284
+1-800-521-6274 or +1-480-768-2130
www.freescale.com/support

Europe, Middle East, and Africa:

Freescale Halbleiter Deutschland GmbH
Technical Information Center
Schatzbogen 7
81829 Muenchen, Germany
+44 1296 380 456 (English)
+46 8 52200080 (English)
+49 89 92103 559 (German)
+33 1 69 35 48 48 (French)
www.freescale.com/support

Japan:

Freescale Semiconductor Japan Ltd.
Headquarters
ARCO Tower 15F
1-8-1, Shimo-Meguro, Meguro-ku,
Tokyo 153-0064
Japan
0120 191014 or +81 3 5437 9125
support.japan@freescale.com

Asia/Pacific:

Freescale Semiconductor China Ltd.
Exchange Building 23F
No. 118 Jianguo Road
Chaoyang District
Beijing 100022
China
+86 10 5879 8000
support.asia@freescale.com

Information in this document is provided solely to enable system and software implementers to use Freescale Semiconductors products. There are no express or implied copyright licenses granted hereunder to design or fabricate any integrated circuits or integrated circuits based on the information in this document.

Freescale Semiconductor reserves the right to make changes without further notice to any products herein. Freescale Semiconductor makes no warranty, representation, or guarantee regarding the suitability of its products for any particular purpose, nor does Freescale Semiconductor assume any liability arising out of the application or use of any product or circuit, and specifically disclaims any liability, including without limitation consequential or incidental damages. "Typical" parameters that may be provided in Freescale Semiconductor data sheets and/or specifications can and do vary in different applications and actual performance may vary over time. All operating parameters, including "Typicals", must be validated for each customer application by customer's technical experts. Freescale Semiconductor does not convey any license under its patent rights nor the rights of others. Freescale Semiconductor products are not designed, intended, or authorized for use as components in systems intended for surgical implant into the body, or other applications intended to support or sustain life, or for any other application in which failure of the Freescale Semiconductor product could create a situation where personal injury or death may occur. Should Buyer purchase or use Freescale Semiconductor products for any such unintended or unauthorized application, Buyer shall indemnify Freescale Semiconductor and its officers, employees, subsidiaries, affiliates, and distributors harmless against all claims, costs, damages, and expenses, and reasonable attorney fees arising out of, directly or indirectly, any claim of personal injury or death associated with such unintended or unauthorized use, even if such claims alleges that Freescale Semiconductor was negligent regarding the design or manufacture of the part.

RoHS-compliant and/or Pb-free versions of Freescale products have the functionality and electrical characteristics as their non-RoHS-complaint and/or non-Pb-free counterparts. For further information, see <http://www.freescale.com> or contact your Freescale sales representative.

For information on Freescale's Environmental Products program, go to <http://www.freescale.com/epp>.

Freescale™ and the Freescale logo are trademarks of Freescale Semiconductor, Inc. All other product or service names are the property of their respective owners.

© 2012 Freescale Semiconductor, Inc.