

UM10371

STARplug buck and buck-boost converter demo board (STARbuck)

Rev. 2 — 4 May 2011

User manual

Document information

Info	Content
Keywords	STARplug, buck converter, buck/boost converter, white goods, non-isolated SMPS
Abstract	<p>The NXP Semiconductors STARbuck demo board is a flexible, user configurable, non-isolated SMPS application intended for low power loads. STARbuck has a universal mains input and a single positive or negative DC voltage output.</p> <p>This manual describes the STARbuck demo board version 1.0.</p> <p>Refer to the TEA152x data sheet for details on the STARplug device and the STARplug application note AN00055 for general application information.</p>



Revision history

Rev	Date	Description
v.2	20110504	second issue
v.1	20100407	first issue

Contact information

For more information, please visit: <http://www.nxp.com>

For sales office addresses, please send an email to: salesaddresses@nxp.com

1. Introduction

WARNING

Lethal voltage and fire ignition hazard



The non-insulated high voltages that are present when operating this product, constitute a risk of electric shock, personal injury, death and/or ignition of fire.

This product is intended for evaluation purposes only. It shall be operated in a designated test area by personnel qualified according to local requirements and labor laws to work with non-insulated mains voltages and high-voltage circuits. This product shall never be operated unattended.

The STARbuck Switched Mode Power Supply (SMPS) demo board has one single non-isolated DC output voltage. The circuit is built around an NXP Semiconductors STARplug IC and the operation mode of the circuit is either buck or buck/boost. The default configuration on the STARbuck demo Printed-Circuit Board (PCB) implements Buck mode operation and produces 5 V (DC) (100 mA maximum) on the output terminals. However, by changing the jumper settings, modifying the component values, or swapping the components, the STARbuck demo board can be adapted easily to meet specific needs with respect to the output voltage and the output current.



Fig 1. STARbuck demo board

2. Features

- Universal mains input
- Single DC voltage output
- Non-isolated, AC mains supply Neutral terminal connected to 0 V (GND) DC output terminal
- Produces either a positive polarity in Buck mode or a negative polarity voltage in Buck/boost mode
- No custom-made magnetic components required; uses only standard components

- User configurable output voltage range between 5 V and 36 V
- User configurable maximum output current set using resistor R3:
 - TEA1520T: up to 125 mA; maximum output power < 2.5 W
 - TEA1521T: up to 250 mA; maximum output power < 5 W
 - TEA1522T: up to 500 mA; maximum output power < 10 W
- High efficiency (at higher output voltages only):
 - TEA1520T: 12 V; 1 W; typical efficiency > 75 %
 - TEA1522T: 12 V; 4 W; typical efficiency > 78 %
- Very low standby (no-load) power (at higher output voltages only):
 - TEA1520T: 12 V; 1 W; typical standby power < 40 mW
 - TEA1522T: 12 V; 4 W; typical standby power < 65 mW
- Overload protection
- OverTemperature Protection (OTP)
- Built-in ElectroMagnetic Interference (EMI) filter

3. Technical specifications

Table 1. Input specification

Parameter	Condition	Value	Remark
input voltage		80 to 276 V (AC)	universal mains
input frequency		47 to 63 Hz	-

Table 2. Output specification

Parameter	Condition	Value	Remark
output voltage		5 V	user changeable
output voltage tolerance	at 75 % load	± 5 %	-
output voltage stability	at 5 V output	+15 %/-5 %	over full power range
	at 12 V output	+10 %/-5 %	over full power range

4. Performance data

4.1 Output voltage and no-load power consumption

[Table 3](#) shows the no-load power consumption figures for three implementations of the STARbuck SMPS:

- TEA1520T: 5 V; 100 mA (500 mW); the default implementation on the demo board
- TEA1520T: 12 V; 83 mA (1 W)
- TEA1522T: -12 V; -333 mA (4 W)

STARplug buck and buck-boost converter demo board (STARbuck)

Table 3. No-load output voltage and power consumption values

Power supply	Energy start 2.0 requirement	Output voltage (V_{out})	Power consumption (P_i)
5 V, 500 mW STARbuck			
115 V/60 Hz	≤ 300 mW	5.6 V	160 mW
230 V/50 Hz	≤ 300 mW	5.6 V	300 mW
12 V, 1 W STARbuck			
115 V/60 Hz	≤ 300 mW	13.0 V	30 mW
230 V/50 Hz	≤ 300 mW	13.0 V	40 mW
-12 V, 4 W STARbuck			
115 V/60 Hz	≤ 300 mW	-13.0 V	30 mW
230 V/50 Hz	≤ 300 mW	-13.0 V	65 mW

4.2 Efficiency performance data

Table 4 shows the efficiency figures for three implementations of the STARbuck SMPS:

- TEA1520T: 5 V; 100 mA (500 mW); the default implementation on the demo board
- TEA1520T: 12 V, 83 mA (1 W)
- TEA1522T: -12 V, -333 mA (4 W)

Table 4. Efficiency values

Power supply	Energy star requirement	Efficiency (η)				
		average	25 % load	50 % load	75 % load	100 % load
5 V, 500 mW STARbuck						
115 V/60 Hz	31.6 %	50.6 %	39.3 %	50.2 %	55.4 %	57.5 %
230 V/50 Hz	31.6 %	40.1 %	30.7 %	37.5 %	44.0 %	48.4 %
12 V, 1 W STARbuck						
115 V/60 Hz	62.2 %	80.6 %	78.3 %	79.9 %	83.0 %	81.2 %
230 V/50 Hz	62.2 %	75.7 %	69.2 %	74.5 %	79.1 %	80.1 %
-12 V, 4 W STARbuck						
115 V/60 Hz	70.9 %	80.5 %	80.0 %	82.6 %	80.9 %	78.6 %
230 V/50 Hz	70.9 %	78.6 %	74.0 %	78.6 %	80.8 %	80.9 %

Remark: Warm-up time is 15 minutes. Settle time after the load change is 90 s.

4.3 Electro-Magnetic Compatibility (EMC) performance data

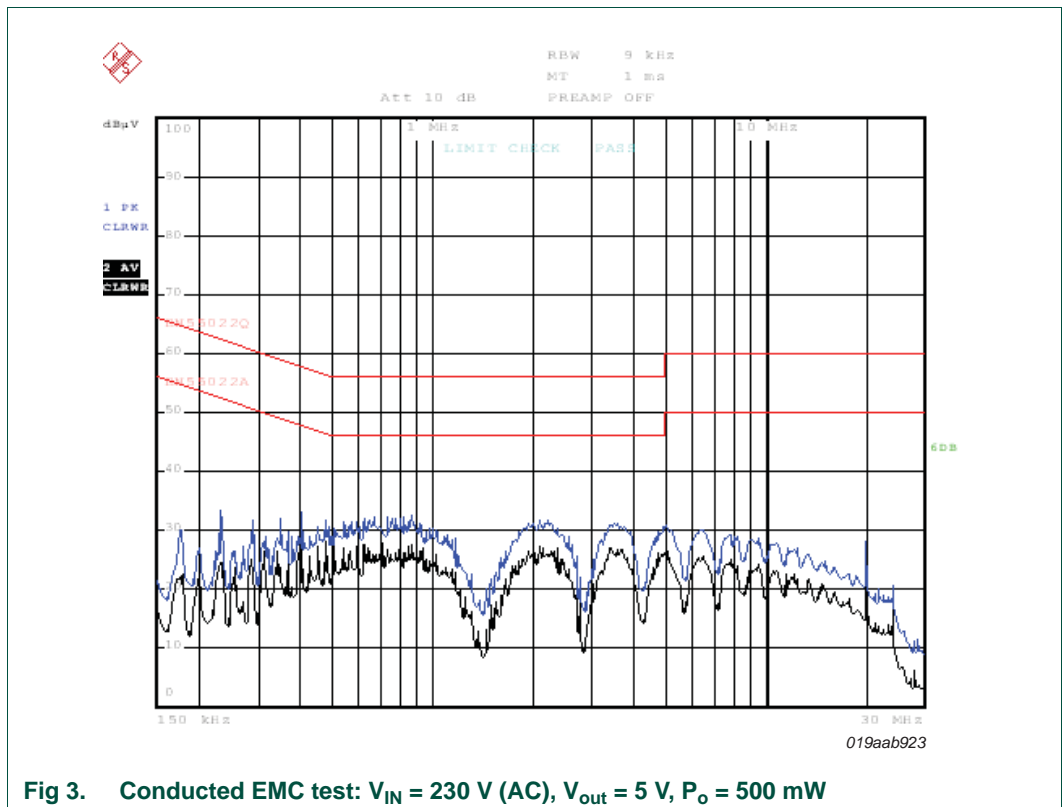
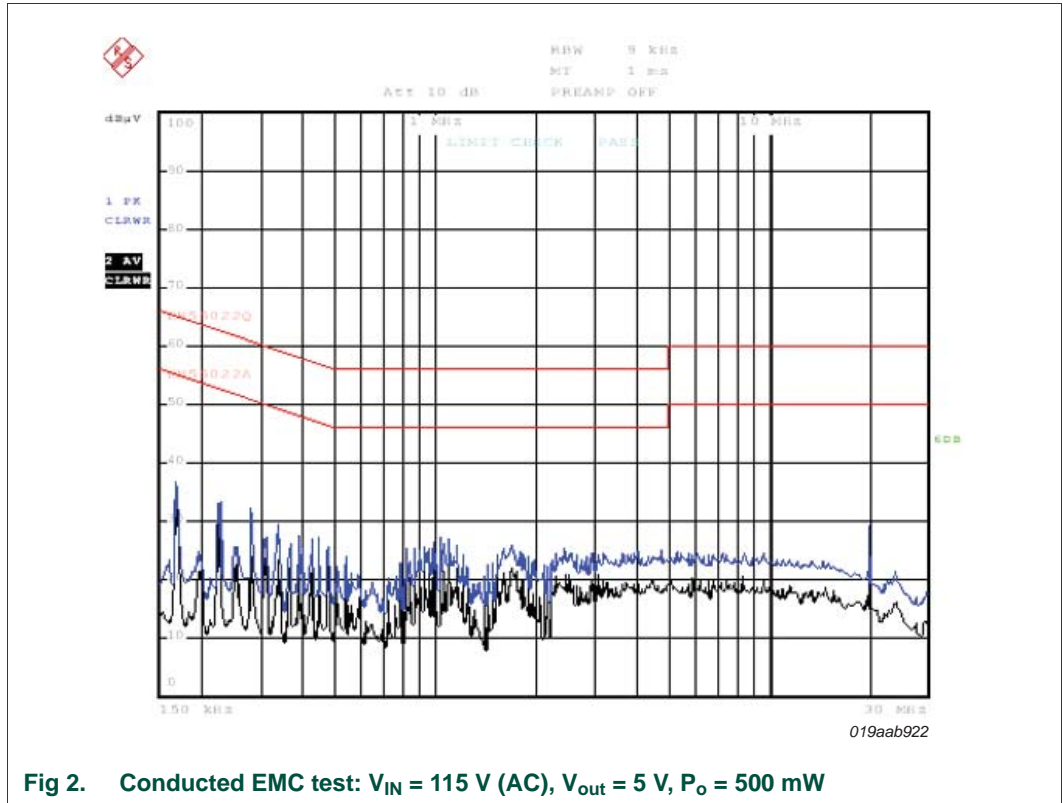

STARplug buck and buck-boost converter demo board (STARbuck)

Both the average and quasi-peak EMC performance of the STARbuck demo board meet the requirements of EN55022.

5. Connection of the demo board

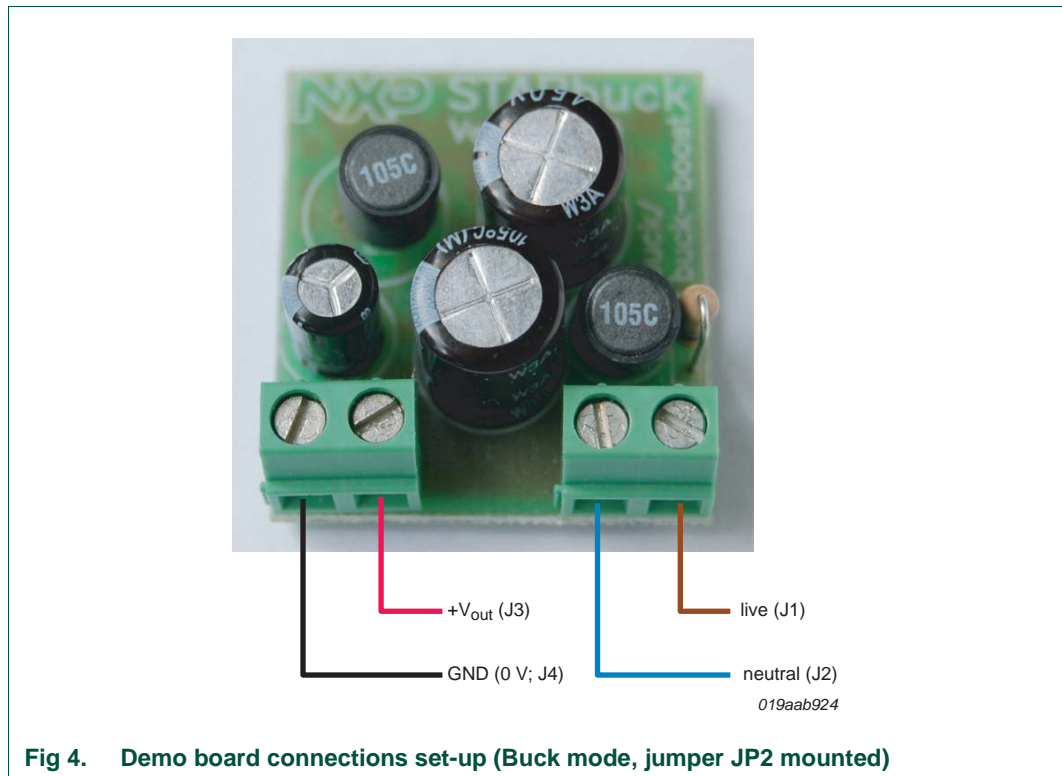

In Buck mode J2 (neutral) is connected to J4 (GND). The output voltage ($+V_{out}$) on J3 has a positive polarity with respect to GND.

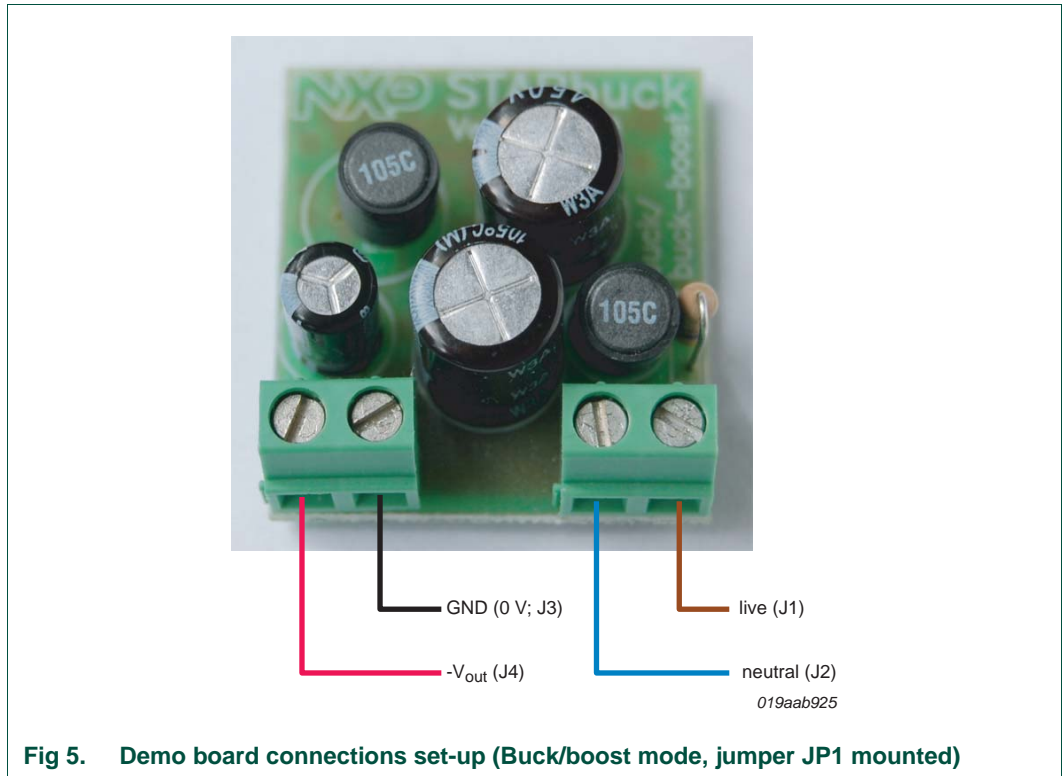

In Buck/boost mode J2 (neutral) is connected to J3 (GND). The output voltage ($-V_{out}$) on J4 has a negative polarity with respect to GND.

6. Circuit description

The default STARbuck demo board consists of a single-phase half wave rectifier circuit, a filtering section, a switching section, an output section and a feedback section. The full default circuit diagram implemented on the STARbuck demo board PCB is shown in [Figure 6](#).

6.1 Rectification section

The single phase, half wave rectifier consists of a single diode (D1). Capacitor C1 functions as a reservoir capacitor for the rectified input voltage. The inrush current is limited by resistor R1. Connectors J1 (live) and J2 (neutral) connect the input to the electricity utility network. Swapping live and neutral, however, does not have any effect on the operation of the STARbuck converter.

The half wave rectifier circuit allows the neutral terminal to have the same potential level as the GND terminal. This enables the triacs and SCRs to be driven from a logic circuit powered by the STARbuck SMPS. This is for example, a common approach in white goods applications that do not require AC mains supply isolation.

6.2 Filtering section

The filtering section which consists of L1 and C2, effectively reduces the noise and harmonic content that would otherwise be injected from the TEA152x switching electronics into the electricity utility network. This circuit aids in achieving the EMC performance required by EN55022.

6.3 Switching section

The switching section uses a standard NXP Semiconductors STARplug TEA152xT IC in an SO14 package. The operating frequency is set by the combination of R2 and C3. Resistor R3 limits the peak current that can occur in the STARplug internal MOSFET switch and consequently in inductor L2. The current limitation simultaneously prevents the internal MOSFET switch from being overstressed (the maximum switch current is given in [Equation 1](#)) and the output current of the SMPS from exceeding the value in [Equation 2](#). In this way a programmable overload protection is built into the application.

$$I_{DS(max)} = \frac{0.5}{R3} \quad (1)$$

$$I_{o(max)} = \frac{0.25}{R3} \quad (2)$$

At low DC output voltages ($V_{out} \leq 10$ V), the STARplug IC must provide its own operating voltage supply (V_{CC}). It does this using the internal JFET current source built into the TEA152x family of ICs by buffering the supply voltage on the V_{CC} pin (pin 1) using a 220 nF capacitor (C7).

Remark: This way of generating the V_{CC} supply voltage has negative consequences for the total efficiency and for the no-load power consumption of the SMPS. However, for low output voltages there is no straightforward solution that is more efficient and economically feasible.

The AUX pin of the IC (pin 8) receives information regarding the magnetization status of the inductor L2 via the two resistors R6 and R7. The resistor was divided in to two parts because of the relatively high voltage that can appear across R6/R7.

6.4 Output section

The output section of the STARbuck application consists of D2, L2, C6 and D3. Jumpers JP1 and JP2 (1206 SMD jumpers) are used to select either the Buck mode or Buck/boost mode as the operating mode. The freewheel diode D2 acts as the lower switch in the buck (or buck/boost) converter. L2 is the primary energy storage element of this application and C6 buffers the output voltage and reduces output voltage ripple.

The Zener diode D3 prevents the output of the SMPS rising too high above the nominal programmed output voltage under low load or no-load conditions. This unwanted voltage increase is a consequence of the switching spikes that occur in the Switching section. This can be effectively countered using a low power Zener diode.

6.5 Feedback section

The feedback section consists of D4, C5, R4, R5 and C4. With diode D4 and capacitor C5, the voltage across C6 (V_{out}) is more or less “copied” and level shifted to the C5 voltage. Resistors R4 and R5 form a voltage divider with an output to the STARplug REG pin (pin 7). The programmed output voltage of the STARbuck SMPS is given in [Equation 3](#).

$$V_{out} = 2.5 \cdot \frac{R4 + R5}{R5} \quad (3)$$

Capacitor C4 acts as a noise suppressor in the feedback regulation circuit and adds a pole to the feedback loop.

Refer to the *STARplug application note AN00055* for more detailed/accurate information on the operation of STARplug TEA152x and the dimensioning of STARplug circuits.

7. Alternative circuit options

7.1 Buck/boost converter circuit

Instead of implementing a buck converter as shown in [Figure 6](#), a buck/boost converter circuit can be realized by removing jumper JP2 and mounting jumper JP1. Note the required wiring diagram changes (see [Section 5](#)). The output voltage has a negative polarity with respect to GND. See the circuit diagram shown in [Figure 7](#) and the component changes in [Table 9](#).

7.2 Buck or buck/boost converter with an output voltage > 10 V

When the output voltage of the buck (or buck/boost) converter is above 10 V, the output voltage can simultaneously be used to supply the internal electronics of the TEA152x IC through its V_{CC} pin. A provision is made on the STARbuck demo board PCB enabling jumper JP3 (1206 SMD jumper) to be mounted so that it connects the feedback voltage across C5 to the IC V_{CC} pin.

When the V_{CC} pin is powered externally, the internal JFET current source stops operating, saving a considerable amount of power. When jumper JP3 is mounted, the capacitors C5 and C7 are operate completely in parallel. This makes it possible to eliminate C7, if the value of C5 is increased.

[Table 3](#) shows that the no-load power consumption drops drastically when compared to the situation where the output voltage is too low to mount JP3 (see [Table 3](#)). The efficiency is also increased significantly when this circuit option is implemented.

The circuit diagram shown in [Figure 8](#) and the component changes indicated in [Table 10](#) show a STARbuck application with 12 V output voltage and a maximum output current of 350 mA.

7.3 V_{CC} voltage spike suppression

When the STARplug V_{CC} pin is powered externally harsh environments may induce voltage spikes on the V_{CC} pin via the output section of the STARbuck circuit. A voltage spike above 40 V can damage the STARplug IC. Voltage spikes can be suppressed by mounting a Zener diode (D5) in the position of C7 and replacing JP3 with a small (10 Ω) 1206-sized resistor (R8). See the circuit diagram in [Figure 9](#) and the component changes in [Table 11](#).

7.4 Increased current capability

As described in [Section 6.3](#), both the maximum current through the STARplug's internal MOSFET and the SMPS' maximum output current can be programmed by changing the R3 resistor value. [Equation 1](#) and [Equation 2](#) show the relationships. Care must be taken that the programmed maximum drain-source current ($I_{DS(max)}$) value does not exceed the maximum current capability of the TEA152xT device that is mounted on the PCB.

[Table 5](#) shows the $I_{DS(max)}$ values that are tolerable for the respective TEA152x family members.

Table 5. STARplug IC family members' current capability

STARplug family member	$I_{DS(max)}$	Maximum STARbuck output current (I_o)	Lowest tolerable R3 value
TEA1520T	250 mA	125 mA	2 Ω
TEA1521T	500 mA	250 mA	1 Ω
TEA1522T	1000 mA	500 mA	0.5 Ω

The L2 inductor value and current capability must be adapted to meet the requirements of higher current outputs. Guidelines can be found in the *AN00055 STARplug application note*.

A small output voltage limiting diode (BZX384) in the D3 position is sufficient for low output power STARbuck versions. If such a small Zener diode in the D3 position becomes too hot, the STARbuck PCB has a provision for mounting an SMA-sized Zener diode (e.g. Vishay BZG03) in the same position.

The value of the inrush current reduction resistor must be adapted. [Table 6](#) gives suggested values for various conditions.

Finally, it is suggested to adapt the value of the C1 and C2 reservoir capacitors. See [Table 7](#). The values proposed in [Table 6](#) and [Table 7](#) are not the optimal values for an end application but these values should work fine for the initial evaluation of a STARbuck application.

Remark: It is recommended to carry out the proper calculations for the specific STARbuck implementation for an end application.

Table 6. Suggested R1 inrush current limiting resistor values

Input voltage (V _{IN})	Output power (P _o)				
	1 W	2 W	4 W	7 W	10 W
115 V (AC)	47 Ω	47 Ω	33 Ω	22 Ω	22 Ω
230 V (AC)	47 Ω	47 Ω	47 Ω	33 Ω	33 Ω

Remark: The R1 resistor must be a carbon film type. A metal film resistor could act as a fuse instead of an inrush current limiter.

Table 7. Suggested C1 and C2 reservoir capacitor values

Input voltage (V _{IN})	Output power (P _o)				
	1 W	2 W	4 W	7 W	10 W
115 V (AC)	2.2 μF	2.2 μF	4.7 μF	6.8 μF	10 μF
230 V (AC)	2.2 μF	2.2 μF	2.2 μF	4.7 μF	6.8 μF

7.5 Reduced EMI filtering

Applications that do not require a high level of EMI filtering can eliminate the L1 and C2 components from the STARbuck demo board PCB, further reducing the cost. The L1 inductor must be replaced with a wire bridge. See the circuit diagram shown in [Figure 10](#) and the component changes shown in [Table 12](#).

8. Schematics

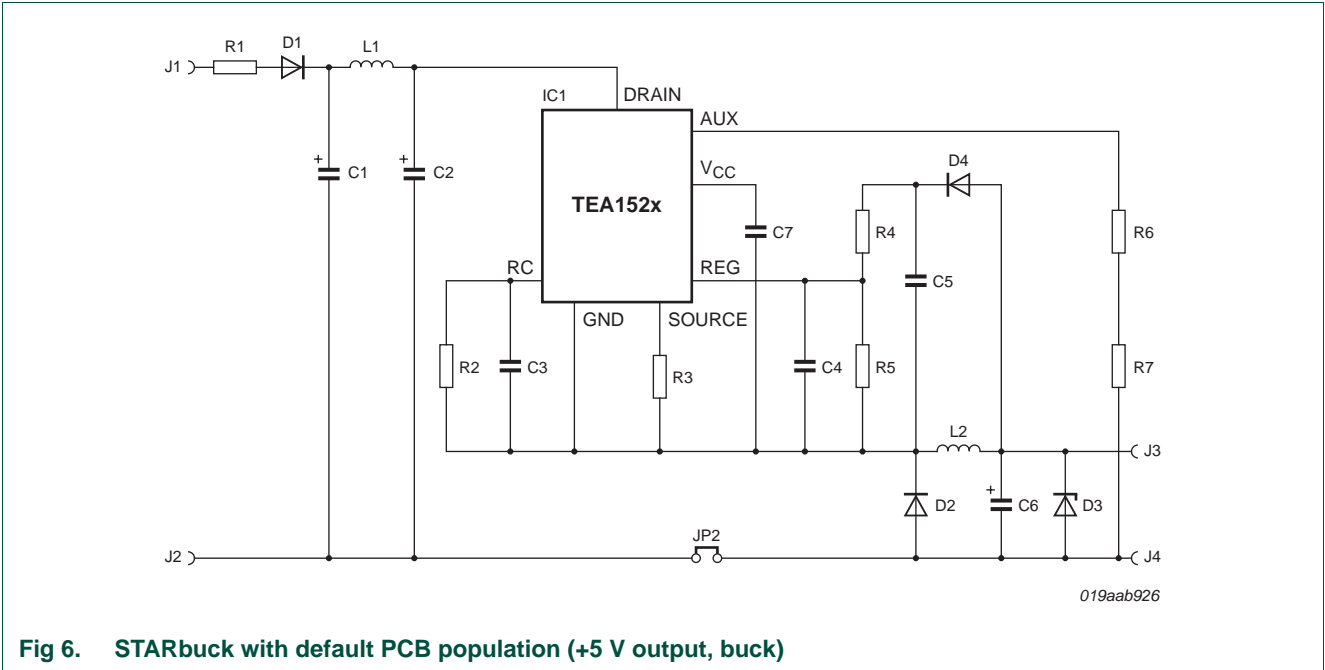

Fig 6. STARbuck with default PCB population (+5 V output, buck)

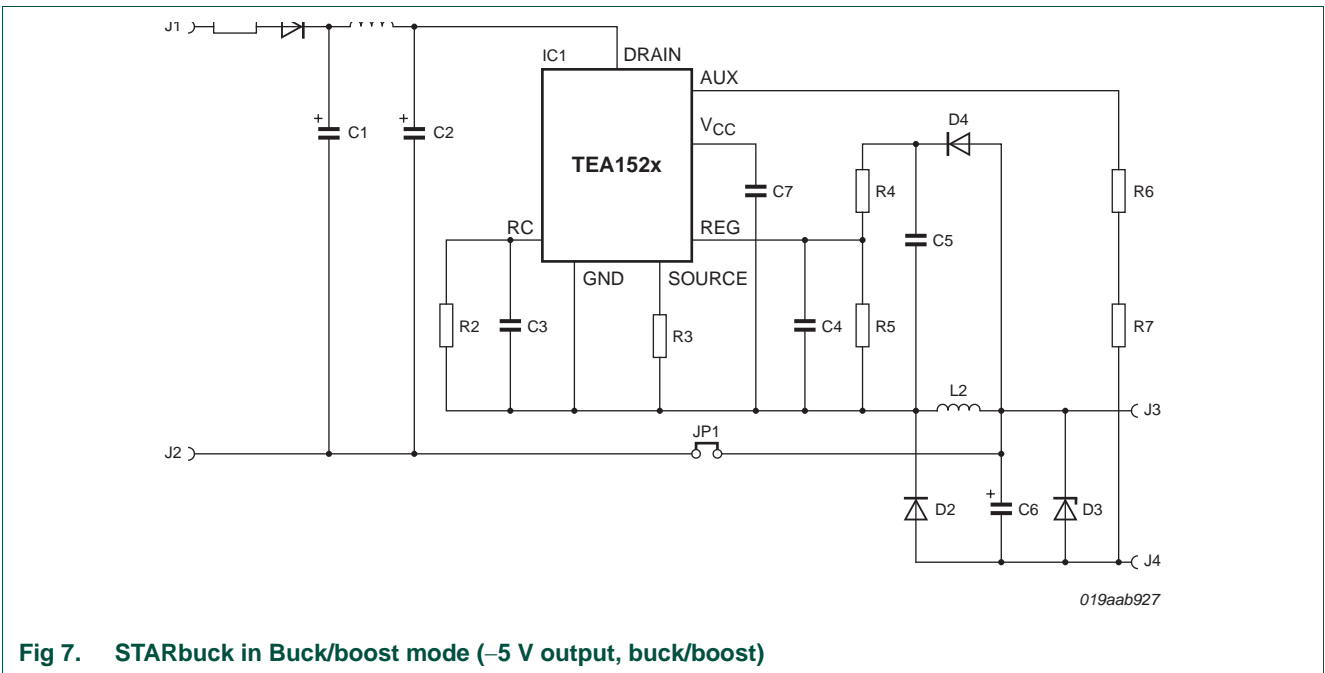

Fig 7. STARbuck in Buck/boost mode (-5 V output, buck/boost)

STARplug buck and buck-boost converter demo board (STARbuck)

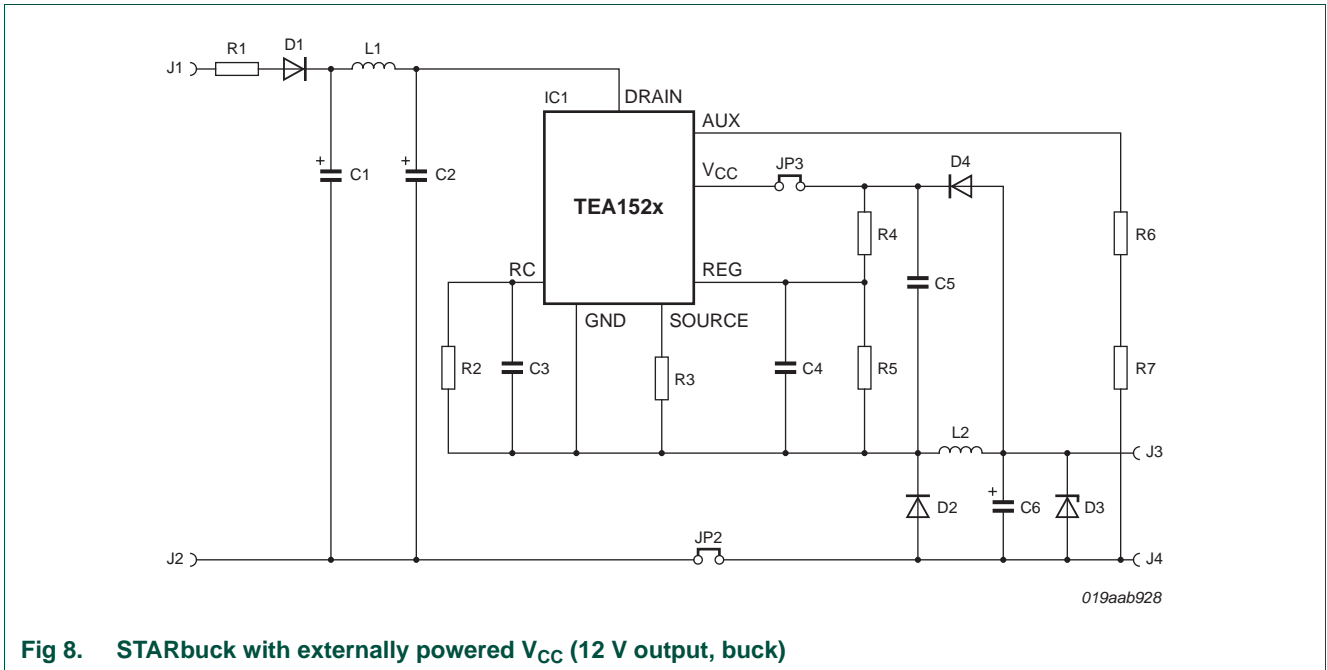

Fig 8. STARbuck with externally powered V_{CC} (12 V output, buck)

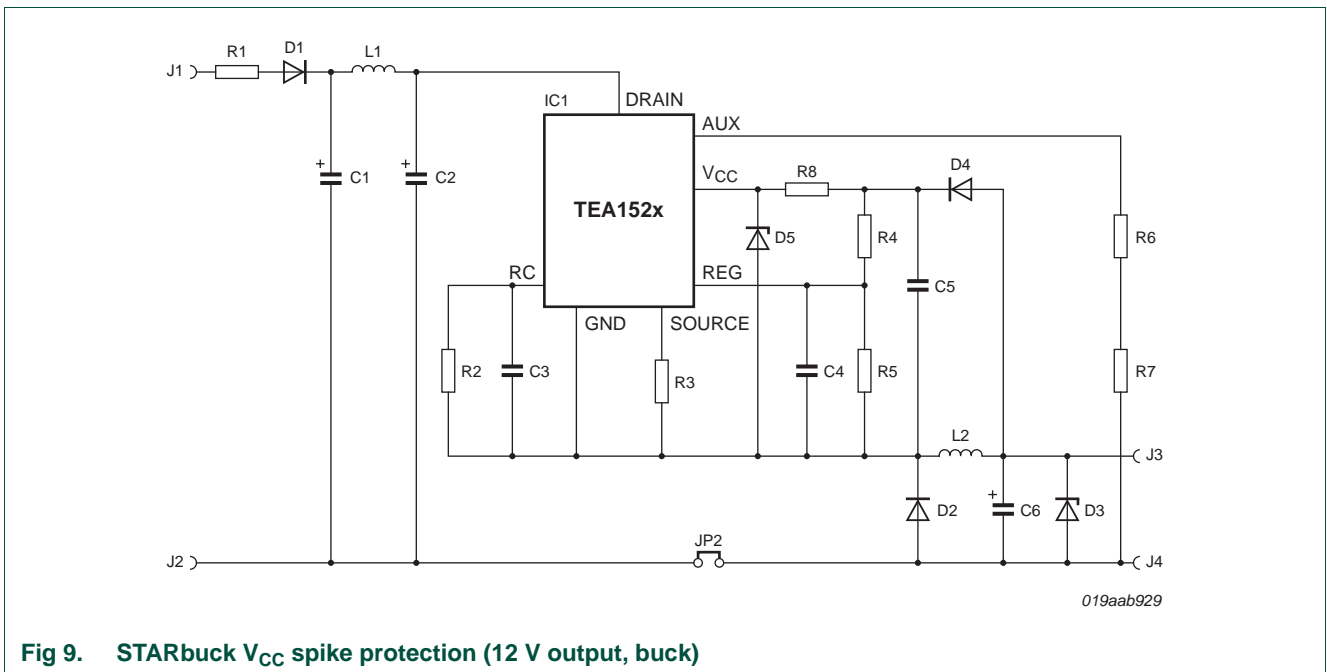

Fig 9. STARbuck V_{CC} spike protection (12 V output, buck)

STARplug buck and buck-boost converter demo board (STARbuck)

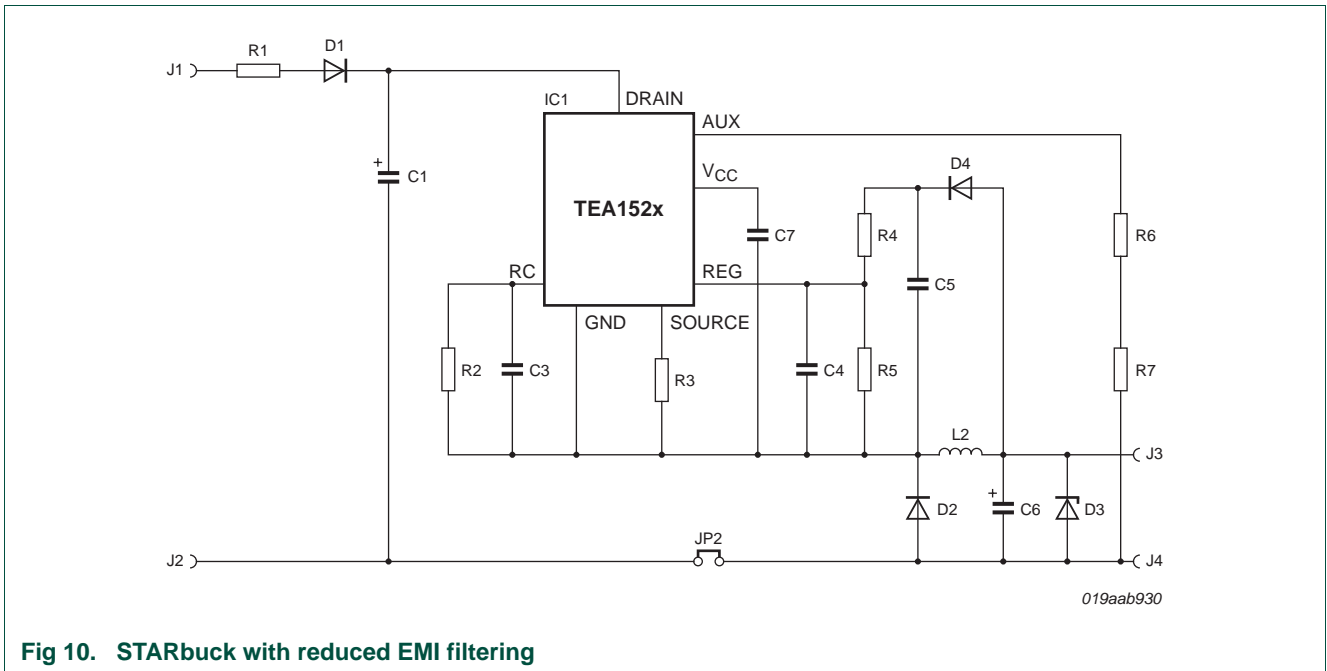

Fig 10. STARbuck with reduced EMI filtering

9. Component lists

Table 8. Default component list

Reference	Component	Package	Remarks
IC1	NXP Semiconductors TEA1520T	SO14	-
D1	Vishay S1M	DO214-AC	-
D2	Vishay FR1J	DO214-AC	-
D3 ^[1]	Vishay BZG03C5V6	DO214-AC	-
D3(A)	NXP BZX384C5V6	SOD323	-
D4	Vishay FR1J	DO214-AC	-
L1	inductor ELC06D, 1 mH	-	e.g. Murata 22R105C
L2	inductor ELC06D, 1 mH	-	e.g. Murata 22R105C
C1	2.2 μ F, 400 V, elcap	radial; 2E	maximum diameter 10.5 mm
C2	2.2 μ F, 400 V, elcap	radial; 2E	maximum diameter 10.5mm
C3	330 pF, 50 V	0805	-
C4	5.6 nF, 50 V	0805	-
C5	100 nF, 50 V	0805	-
C6	220 μ F, 16 V, elcap	radial; 1E	maximum diameter 8 mm
C7	220 nF, 50 V	1206	-
R1	47 Ω , 0.5 W, carbon film	radial; 1E	mounted upright
R2	7.5 k Ω	0805	-
R3	2.2 Ω , 0.25 W	1206	-
R4	5.6 k Ω	0805	-
R5	5.6 k Ω	0805	-
R6	200 k Ω	1206	-
R7	200 k Ω	1206	-
JP1 ^[1]	0 Ω SMD jumper	1206	-
JP2	0 Ω SMD jumper	1206	-
JP3 ^[1]	0 Ω SMD jumper	1206	-
J1/J2	2-pole terminal block	2E pitch	Phoenix: 1729128, Farnell: 304-1440
J3/J4	2-pole terminal block	2E pitch	Phoenix: 1729128, Farnell: 304-1440

[1] Not mounted.

Table 9. Component list modification for buck/boost converter option

Reference	Component	Package	Remarks
JP1	0 Ω SMD jumper	1206	-
JP2 ^[1]	0 Ω SMD jumper	1206	-

[1] Not mounted.

STARplug buck and buck-boost converter demo board (STARbuck)

Table 10. Component list modification for externally powered V_{CC}

Reference	Component	Package	Remarks
IC1	NXP Semiconductors TEA1522T	SO14	-
D2	Vishay BYG20J	DO214-AC	-
D3(A)	NXP BZX384C13	SOD323	-
D4	Vishay BYG20J	DO214-AC	-
L2	inductor 390 μ H	-	$I_i > 400$ mA (DC); $I_{SAT} > 800$ mA
C5	330 nF, 50 V	0805	-
C7 ^[1]	-	1206	-
R3	0.68 Ω , 0.25 W	1206	-
R4	16 k Ω	0805	-
R5	4.3 k Ω	0805	-
JP3	0 Ω SMD jumper	1206	-

[1] Not mounted.

Table 11. Component list modification for externally powered V_{CC} with spike protection

Reference	Component	Package	Remarks
IC1	NXP Semiconductors TEA1522T	SO14	-
D2	Vishay BYG20J	DO214-AC	-
D3(A)	NXP Semiconductors BZX384C13	SOD323	-
D4	Vishay BYG20J	DO214-AC	-
D5	NXP Semiconductors BZX384C27	SOD323	mount in C7 position
L2	inductor 390 μ H	-	$I_i > 400$ mA (DC); $I_{SAT} > 800$ mA
C5	330 nF, 50 V	0805	-
C7 ^[1]	-	1206	-
R3	0.68 Ω , 0.25 W	1206	-
R4	16 k Ω	0805	-
R5	4.3 k Ω	0805	-
R8	10 Ω	1206	mount in JP3 position
JP3 ^[1]	0 Ω SMD jumper	1206	-

[1] Not mounted.

Table 12. Component list modification for reduced EMI filtering

Reference	Component	Package	Remarks
L1 ^[1]	-	-	-
C2 ^[1]	-	radial; 2E	-
JP4	Wire bridge jumper	-	mount in L1 position

[1] Not mounted.

10. Printed-circuit board

The STARbuck SMPS printed-circuit board is a single-sided board. Dimensions are 34 × 31 mm. The demo boards are produced on 1.6 mm FR4 with single sided 35 μm copper (1 Oz.). FR2 could also be used as the PCB material.

The PCB can be configured to provide a number of NXP Semiconductors STARbuck SMPS implementations. With the default component population a tiny 5 V/100 mA power supply is created. The same PCB can be used, however, to create a 12 V/350 mA or even a 24 V/400 mA non-isolated SMPS.

The Gerber File set for the production of the PCB is available from NXP Semiconductors. Normally, the bottom silk is not used for PCB production - it is only a component position reference.

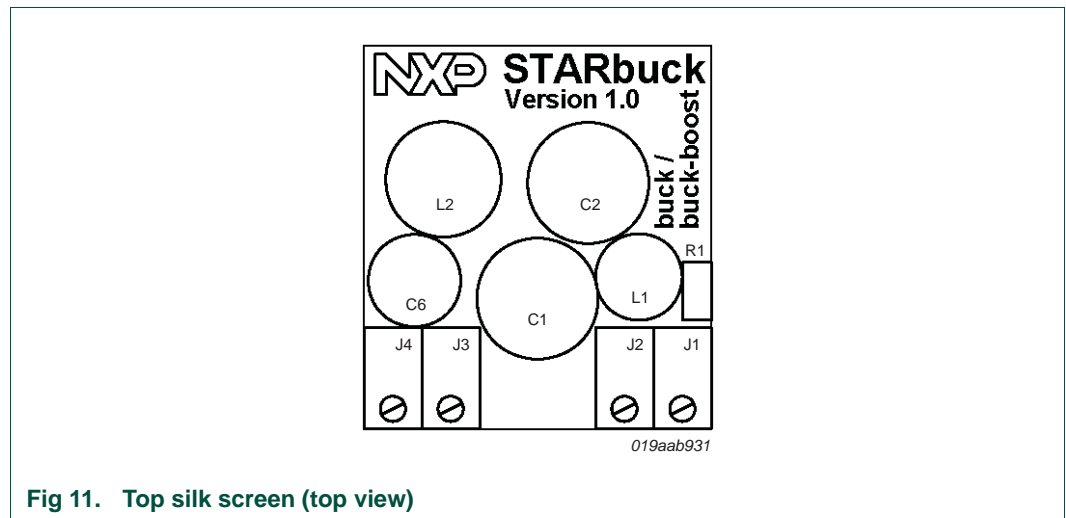

Fig 11. Top silk screen (top view)

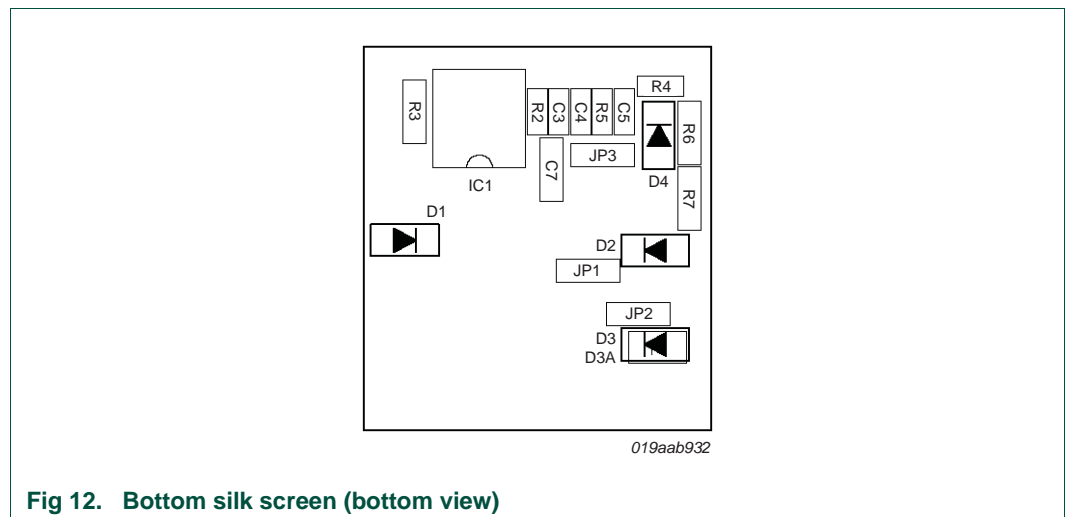
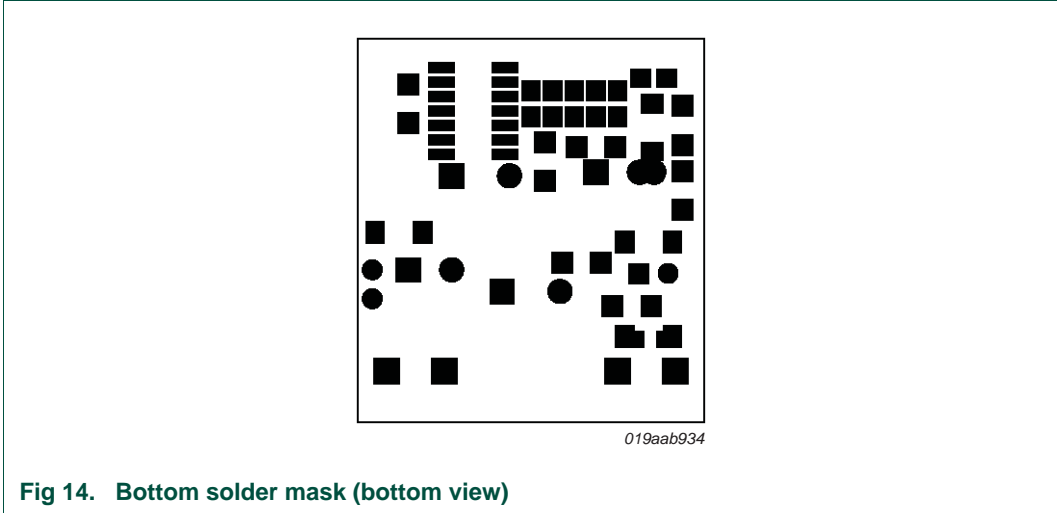
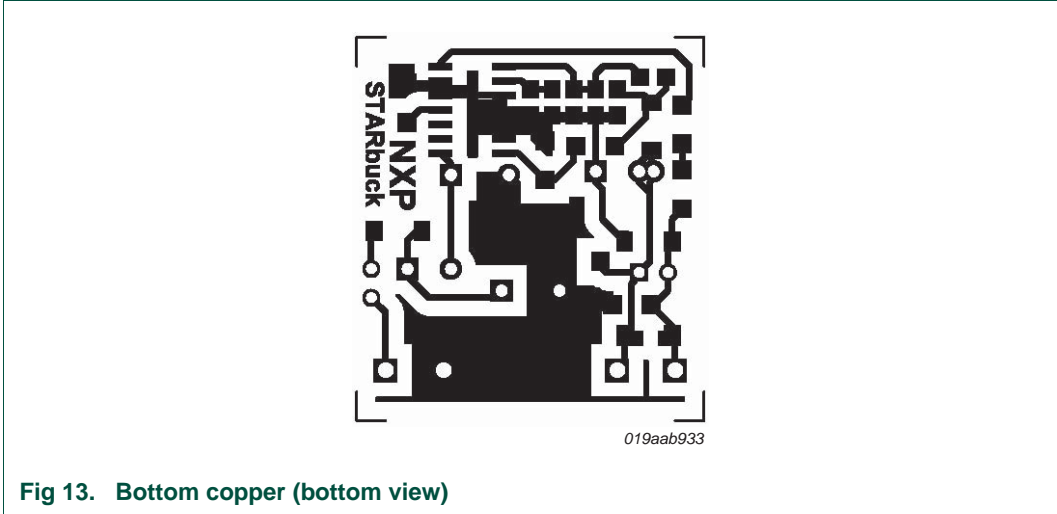

Fig 12. Bottom silk screen (bottom view)



11. Legal information

11.1 Definitions

Draft — The document is a draft version only. The content is still under internal review and subject to formal approval, which may result in modifications or additions. NXP Semiconductors does not give any representations or warranties as to the accuracy or completeness of information included herein and shall have no liability for the consequences of use of such information.

11.2 Disclaimers

Limited warranty and liability — Information in this document is believed to be accurate and reliable. However, NXP Semiconductors does not give any representations or warranties, expressed or implied, as to the accuracy or completeness of such information and shall have no liability for the consequences of use of such information.

In no event shall NXP Semiconductors be liable for any indirect, incidental, punitive, special or consequential damages (including - without limitation - lost profits, lost savings, business interruption, costs related to the removal or replacement of any products or rework charges) whether or not such damages are based on tort (including negligence), warranty, breach of contract or any other legal theory.

Notwithstanding any damages that customer might incur for any reason whatsoever, NXP Semiconductors' aggregate and cumulative liability towards customer for the products described herein shall be limited in accordance with the *Terms and conditions of commercial sale* of NXP Semiconductors.

Right to make changes — NXP Semiconductors reserves the right to make changes to information published in this document, including without limitation specifications and product descriptions, at any time and without notice. This document supersedes and replaces all information supplied prior to the publication hereof.

Suitability for use — NXP Semiconductors products are not designed, authorized or warranted to be suitable for use in life support, life-critical or safety-critical systems or equipment, nor in applications where failure or malfunction of an NXP Semiconductors product can reasonably be expected to result in personal injury, death or severe property or environmental damage. NXP Semiconductors accepts no liability for inclusion and/or use of NXP Semiconductors products in such equipment or applications and therefore such inclusion and/or use is at the customer's own risk.

Applications — Applications that are described herein for any of these products are for illustrative purposes only. NXP Semiconductors makes no representation or warranty that such applications will be suitable for the specified use without further testing or modification.

Customers are responsible for the design and operation of their applications and products using NXP Semiconductors products, and NXP Semiconductors accepts no liability for any assistance with applications or customer product

design. It is customer's sole responsibility to determine whether the NXP Semiconductors product is suitable and fit for the customer's applications and products planned, as well as for the planned application and use of customer's third party customer(s). Customers should provide appropriate design and operating safeguards to minimize the risks associated with their applications and products.

NXP Semiconductors does not accept any liability related to any default, damage, costs or problem which is based on any weakness or default in the customer's applications or products, or the application or use by customer's third party customer(s). Customer is responsible for doing all necessary testing for the customer's applications and products using NXP Semiconductors products in order to avoid a default of the applications and the products or of the application or use by customer's third party customer(s). NXP does not accept any liability in this respect.

Export control — This document as well as the item(s) described herein may be subject to export control regulations. Export might require a prior authorization from national authorities.

Evaluation products — This product is provided on an "as is" and "with all faults" basis for evaluation purposes only. NXP Semiconductors, its affiliates and their suppliers expressly disclaim all warranties, whether express, implied or statutory, including but not limited to the implied warranties of non-infringement, merchantability and fitness for a particular purpose. The entire risk as to the quality, or arising out of the use or performance, of this product remains with customer.

In no event shall NXP Semiconductors, its affiliates or their suppliers be liable to customer for any special, indirect, consequential, punitive or incidental damages (including without limitation damages for loss of business, business interruption, loss of use, loss of data or information, and the like) arising out of the use of or inability to use the product, whether or not based on tort (including negligence), strict liability, breach of contract, breach of warranty or any other theory, even if advised of the possibility of such damages.

Notwithstanding any damages that customer might incur for any reason whatsoever (including without limitation, all damages referenced above and all direct or general damages), the entire liability of NXP Semiconductors, its affiliates and their suppliers and customer's exclusive remedy for all of the foregoing shall be limited to actual damages incurred by customer based on reasonable reliance up to the greater of the amount actually paid by customer for the product or five dollars (US\$5.00). The foregoing limitations, exclusions and disclaimers shall apply to the maximum extent permitted by applicable law, even if any remedy fails of its essential purpose.

11.3 Trademarks

Notice: All referenced brands, product names, service names and trademarks are the property of their respective owners.

STARplug — is a trademark of NXP B.V.

12. Contents

1	Introduction	3
2	Features	3
3	Technical specifications	4
4	Performance data	4
4.1	Output voltage and no-load power consumption	4
4.2	Efficiency performance data	5
4.3	Electro-Magnetic Compatibility (EMC) performance data	6
5	Connection of the demo board	7
6	Circuit description	9
6.1	Rectification section	9
6.2	Filtering section	9
6.3	Switching section	9
6.4	Output section	10
6.5	Feedback section	10
7	Alternative circuit options	10
7.1	Buck/boost converter circuit	10
7.2	Buck or buck/boost converter with an output voltage > 10 V	10
7.3	V _{CC} voltage spike suppression	11
7.4	Increased current capability	11
7.5	Reduced EMI filtering	12
8	Schematics	13
9	Component lists	16
10	Printed-circuit board	18
11	Legal information	20
11.1	Definitions	20
11.2	Disclaimers	20
11.3	Trademarks	20
12	Contents	21

Please be aware that important notices concerning this document and the product(s) described herein, have been included in section 'Legal information'.

© NXP B.V. 2011.

All rights reserved.

For more information, please visit: <http://www.nxp.com>

For sales office addresses, please send an email to: salesaddresses@nxp.com

Date of release: 4 May 2011

Document identifier: UM10371