

UM12075

PCAL9722HN-ARD evaluation board

Rev. 1.0 — 13 June 2024

User manual

Document information

Information	Content
Keywords	PCAL9722HN, ultra low-voltage translating 22-bit SPI I/O expander with Agile I/O features, interrupt output and reset
Abstract	The PCAL9722HN-ARD evaluation board is easy to test and designed for the PCAL9722HN which is a 22-bit general purpose I/O expander that provides remote I/O expansion for most microcontroller families via the SPI interface. The PCAL9722HN-ARD uses the LPC55S69-EVK MCU board to provide an easy to use evaluation platform.



IMPORTANT NOTICE**For engineering development or evaluation purposes only**

NXP provides the product under the following conditions:

This evaluation kit or reference design is for use of **ENGINEERING DEVELOPMENT OR EVALUATION PURPOSES ONLY**.

It is provided as a sample IC pre-soldered to a printed circuit board to make it easier to access inputs, outputs, and supply terminals. This evaluation kit or reference design may be used with any development system or other source of I/O signals by connecting it to the host MCU or computer board via off-the-shelf cables. Final device in an application will be heavily dependent on proper printed circuit board layout and heat sinking design as well as attention to supply filtering, transient suppression, and I/O signal quality.

The product provided may not be complete in terms of required design, marketing, and or manufacturing related protective considerations, including product safety measures typically found in the end device incorporating the product. Due to the open construction of the product, it is the responsibility of the user to take all appropriate precautions for electric discharge. To minimize risks associated with the customers' applications, adequate design and operating safeguards must be provided by the customer to minimize inherent or procedural hazards. For any safety concerns, contact NXP sales and technical support services.

1 Introduction

The PCAL9722HN-ARD evaluation board features a 22-bit general purpose I/O expander that provides remote I/O expansion for most microcontroller families via the SPI interface. The board can be connected in parallel with other SPI-bus demo boards to create an evaluation system.

The IC communicates to the host via the industry standard SPI-bus port. The evaluation software runs under Microsoft Windows 7, 8, and 10 PC platform.

2 Features

- A complete evaluation platform for the PCAL9722HN, Ultra low-voltage translating 22-bit SPI I/O expander with Agile I/O features, interrupt output and reset
- Easy to use GUI based software demonstrates the capabilities of the PCAL9722HN
- On-board LEDs, 7 segment display and key switches for PCAL9722HN general purpose I/O evaluation.
- Convenient test points for easy scope measurements and signal access
- USB interface to the host PC
- Power supply from USB port or external power supply can be used to power PCAL9722HN-ARD evaluation board

3 Finding kit resources and information on the NXP web site

NXP Semiconductors provides online resources for the evaluation board and its supported device(s) on <http://www.nxp.com>.

The information page for PCAL9722HN-ARD evaluation board is at <http://www.nxp.com/PCAL9722HN-ARD>. The information page provides overview information, documentation, software and tools, parametric, ordering information and a **Getting Started** tab.

The Getting Started tab provides quick-reference information applicable to using the PCAL9722HN-ARD evaluation board, including the downloadable assets referenced in this document.

4 Getting ready

Working with the PCAL9722HN-ARD evaluation board requires the kit contents, additional hardware, and a Windows PC workstation with installed software.

4.1 Kit contents

- Assembled and tested evaluation board in an antistatic bag
- Quick Start Guide

4.2 Additional hardware

In addition to the kit components, the following hardware is necessary or beneficial when working with this kit.

- Oscilloscope
- Multimeter for current/voltage measurement
- PC for running GUI

4.3 Assumptions

Familiarity with the SPI-bus is helpful but not required.

4.4 Static handling requirements

CAUTION



This device is sensitive to ElectroStatic Discharge (ESD). Therefore care should be taken during transport and handling. You must use a ground strap or touch the PC case or other grounded source before unpacking or handling the hardware.

4.5 Minimum system requirements

- PC Pentium processor (or equivalent)
- One USB port (either 3.0 or 2.0 or 1.1 compatible)
- Windows 7, 8, 10
- OM13089 MCU board (from www.nxp.com)

4.6 Power requirements

The LPC55S69-EVK MCU board obtains power from the PC USB port, two USB parts can be connected to the LPC55S69-EVK MCU board simultaneously. Please use external power supply option if exceeding the USB port current capabilities.

5 Hardware installation

5.1 PCAL9722HN-ARD EV board and LPC55S69-EVK MCU board connection

PCAL9722HN-ARD evaluation board is connected to the LPC55S69-EVK MCU board using four connectors (J4/J5/J11/J12 on PCAL9722HN-ARD board and P16/P17/P19/P18 on LPC55S69-EVKboard) for SPI-bus and power supply.

The LPC55S69-EVKMCU board communicates with PCAL9722HN demo GUI through PC USB port and uses SPI to communicate to PCAL9722HN.

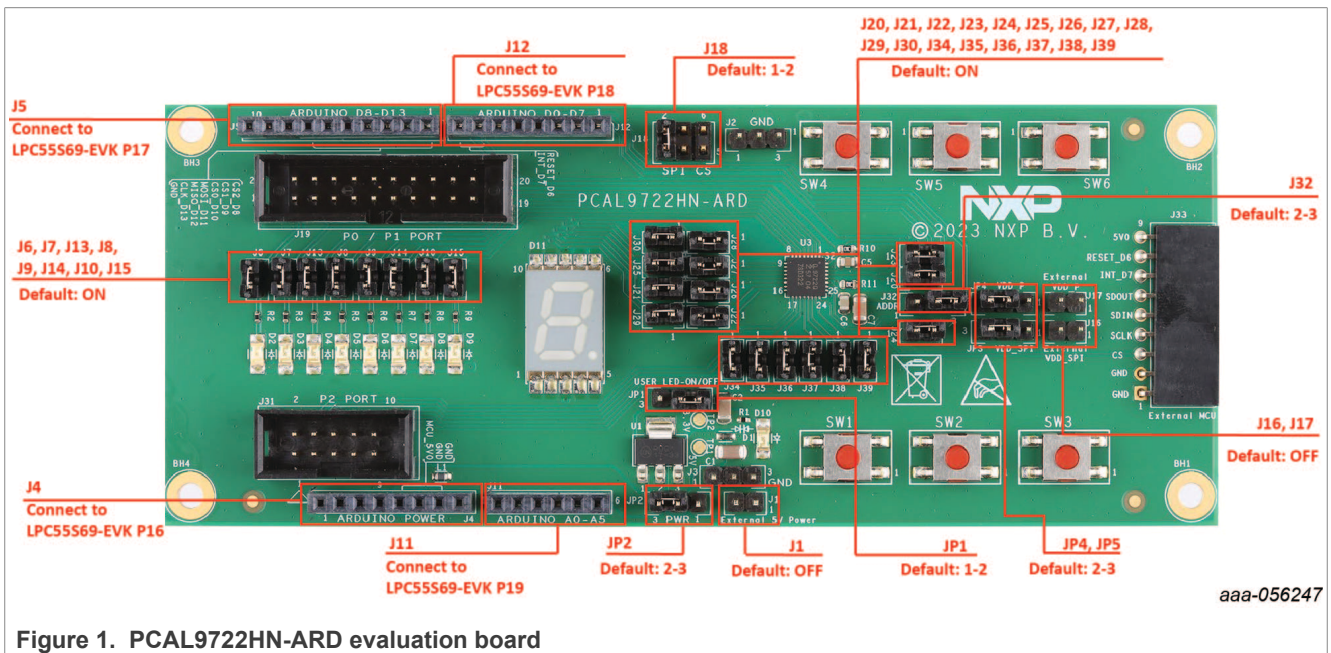
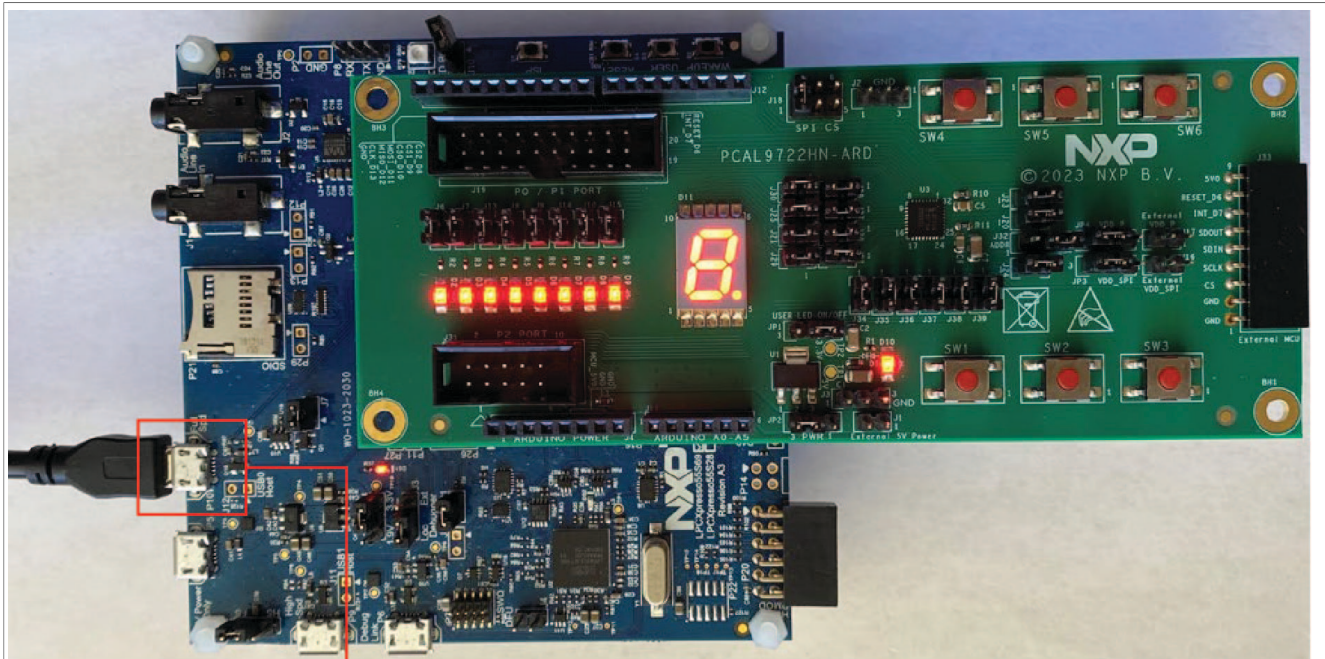

Figure 1. PCAL9722HN-ARD evaluation board



P10
Connect to PC

aaa-056248

Use P10 (USB micro-B connector) on LPC55S69-EVK for power supply and GUI communication port.

Figure 2. PCAL9722HN-ARD evaluation board connecting to the LPC55S69-EVK MCU board

6 Hardware description

- J4/J5/J11/J12 are connected to the LPC55S69-EVKMCU board for PCAL9722HN-ARD power supply and SPI-bus interface.
- JP1 selects user LED on/off.
- JP2 selects internal or external +5V power supply.
- JP3 selects internal or external VDD_SPI power supply.
- JP4 selects internal or external VDD_P power supply.

Table 1. PCAL9722HN-ARD EV board main components

Device	Description	Location
PCAL9722HN	I3C, SPI-bus, 0.5 °C accuracy, digital temperature sensor	U3
7 segment display	Displaying number	D11
NCP117ST33T3G	5V to 3.3V LDO	U1
Red LED	Power supply on LED	D10

Table 2. Jumper settings

Jumper	Default setting	Comment
J4, J5, J11, J12		Arduino connector
J1		External 5V power supply pins
J2, J3		Ground test pins
J6, J7, J13, J8, J9, J14, J10, J15	On	User LED current measurement pins
J16		External VDD_SPI power supply pins
J17		External VDD_P power supply pins
J18	1-2	SPI CS 0-2 select pins
J19		Port 0 and 1 test pins
J20	1-2	SCK test pin
J23	1-2	SDIN test pin
J24	1-2	SDOUT test pin
J21, J22, J25, J26, J27, J28, J29, J30	1-2	7 segment display test pins
J31		Port 2 test pins
J32	2-3	ADDR select pin
J33		External MCU connector
J34, J35, J36, J37, J38, J39	1-2	Key switch test pins
JP1	1-2	User LED on/off select pin
JP2	2-3	Internal or external +5V power supply select pin
JP3	2-3	Internal or external VDD_SPI power supply select pin
JP4	2-3	Internal or external VDD_P power supply select pin

7 Schematic

The schematic diagram of PCAL9722HN-ARD is available at URL: <http://www.nxp.com/PCAL9722HN-ARD>.

8 PCAL9722HN demo GUI

8.1 Install PCAL9722HN-ARD Demo GUI

- Double click on “setup.exe” to install PCAL9722HN-ARD demo GUI.
- Click “Next” button three times to complete installation.

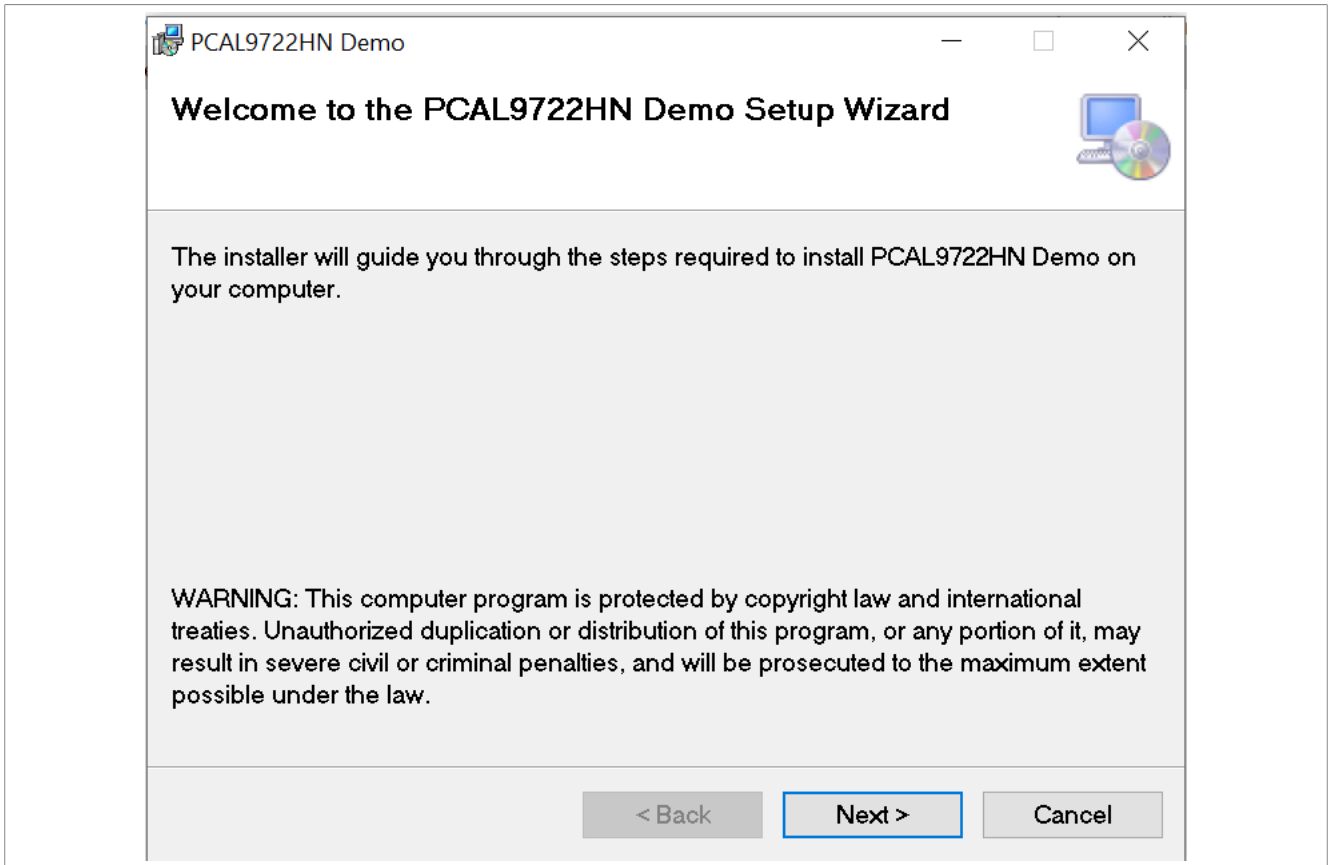

8.2 Run PCAL9722 Demo GUI on Windows 7, 8, and 10 PC

1. Double click on “PCAL9722 Demo” icon to start GUI.

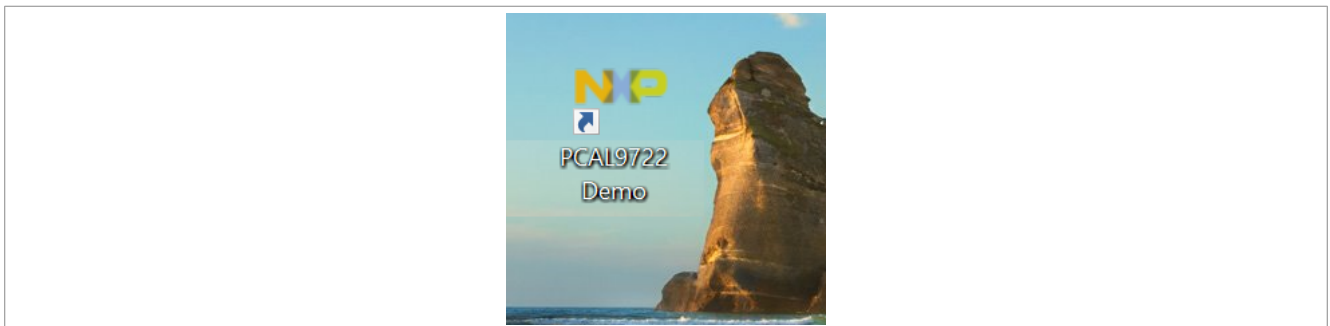

2. Select proper COM port (last COM port normally) and click “Connect” button to connect LPC55S69-EVK board.

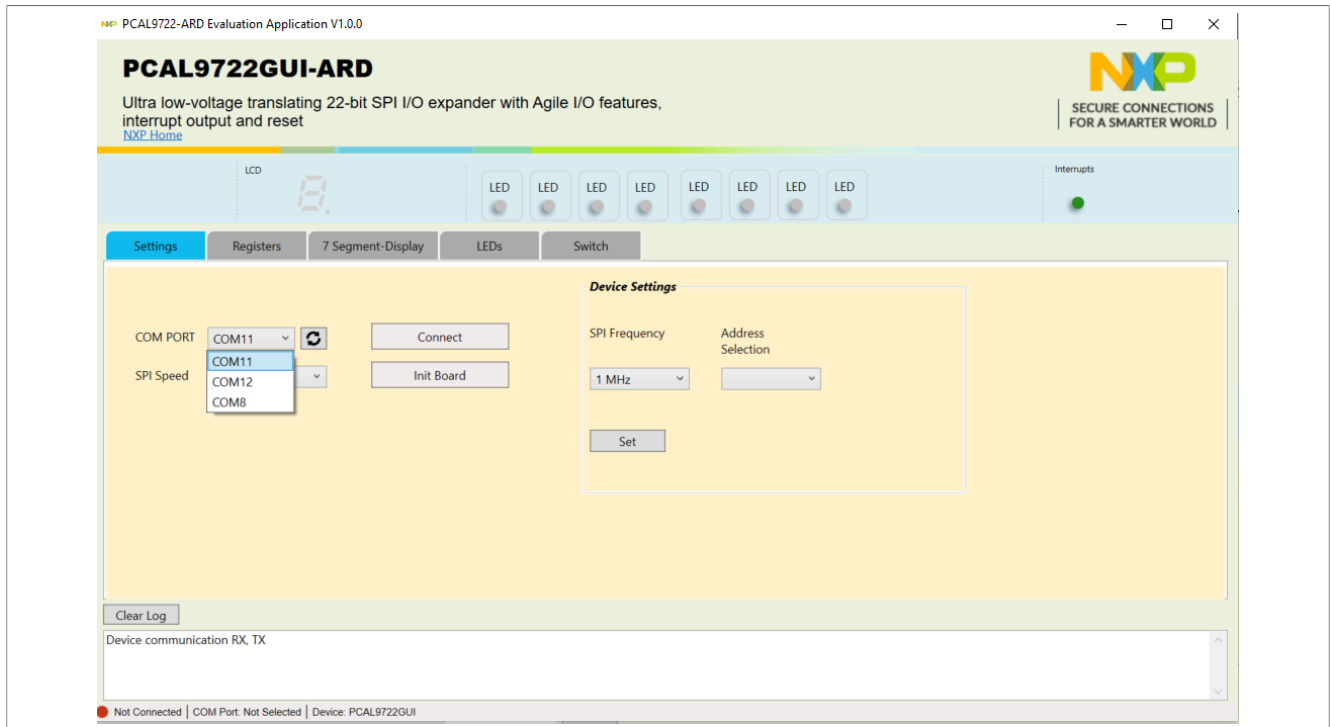

3. Use Setting tab to select SPI speed, and click on the “Init Board” button.

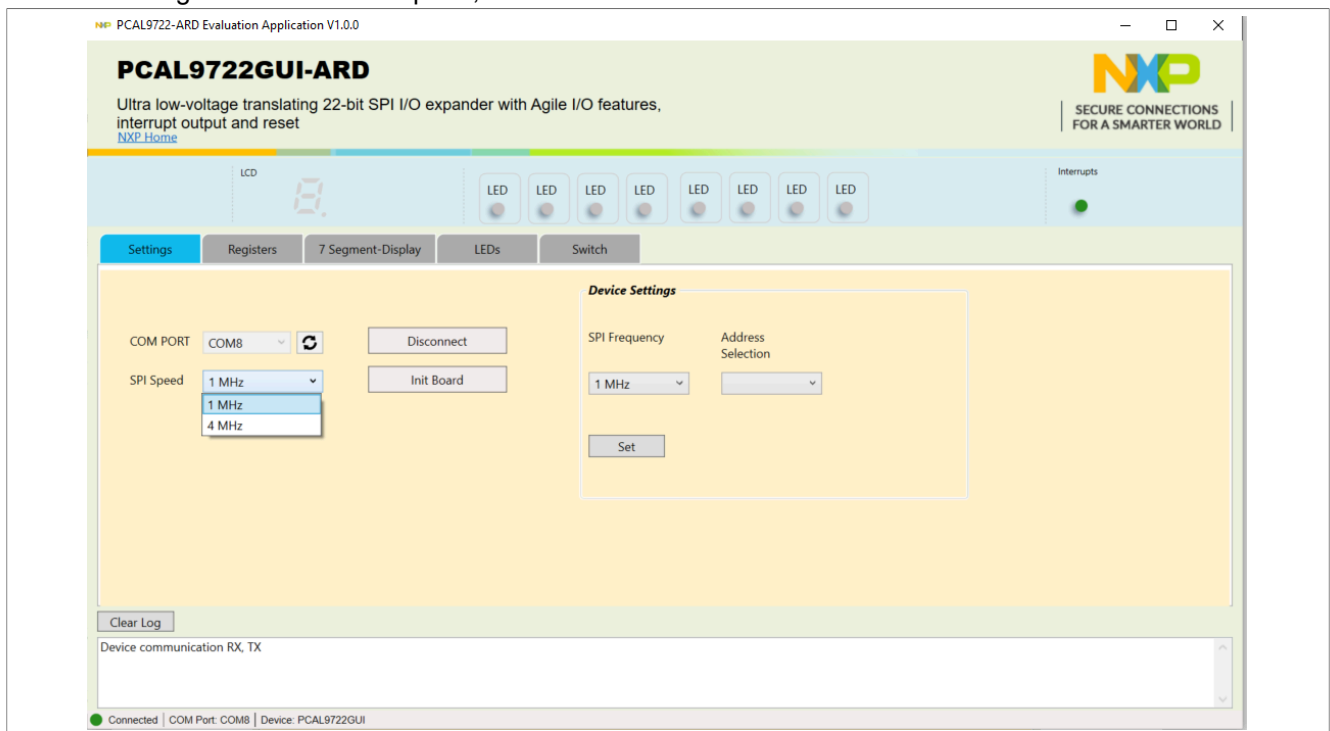

4. Use Register tab “Read Register button” to read out PCAL9722 internal register data and “Save to File” button to save data in a file.

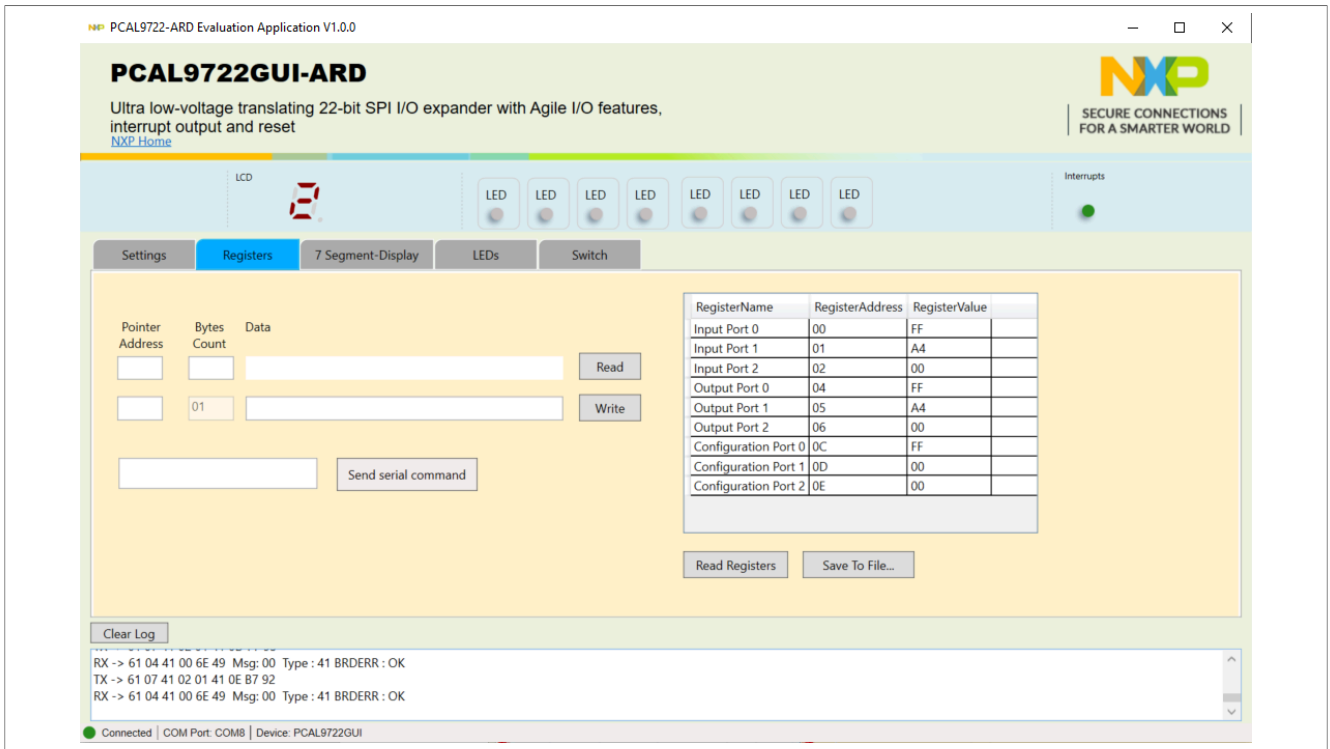

5. Use 7 Segment Display tab to run number up/down on display automatically, or select fix number to be shown on display.

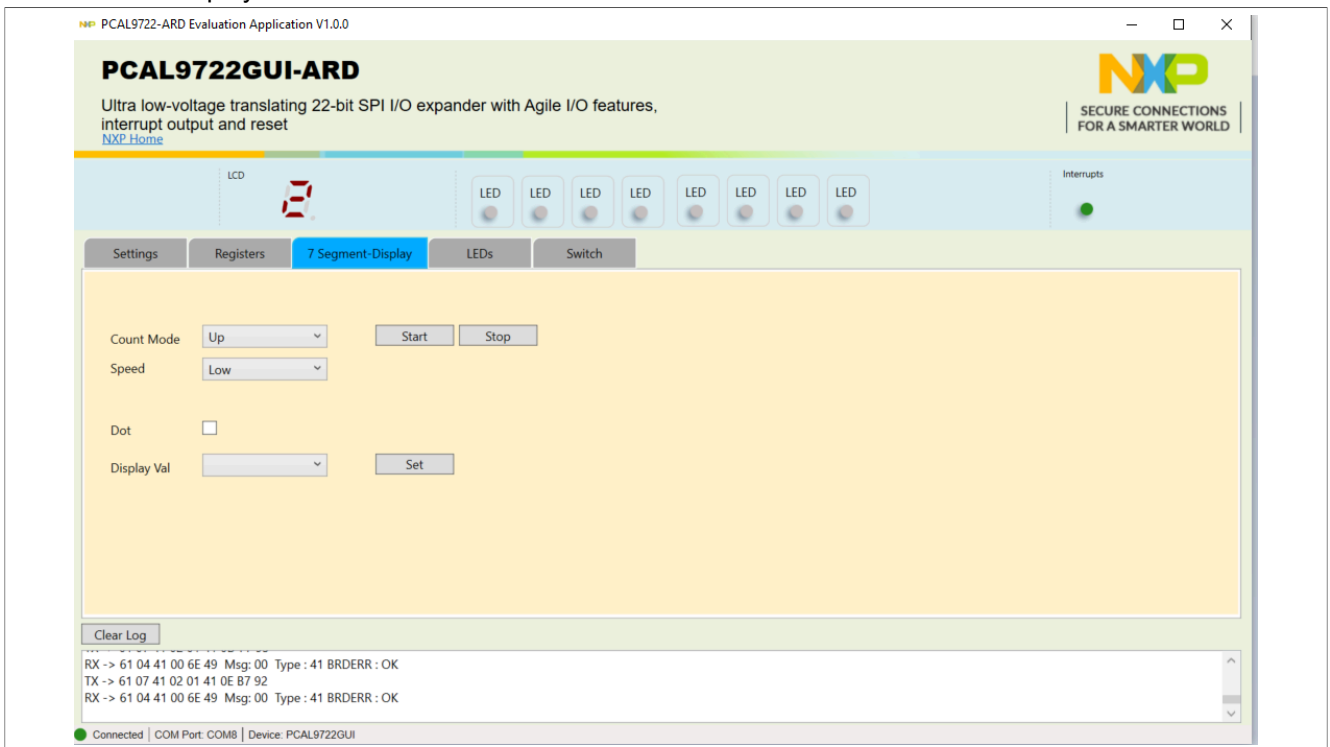

6. Use LED tab to set GPIO drive strength and turn on/off 8 LEDs.

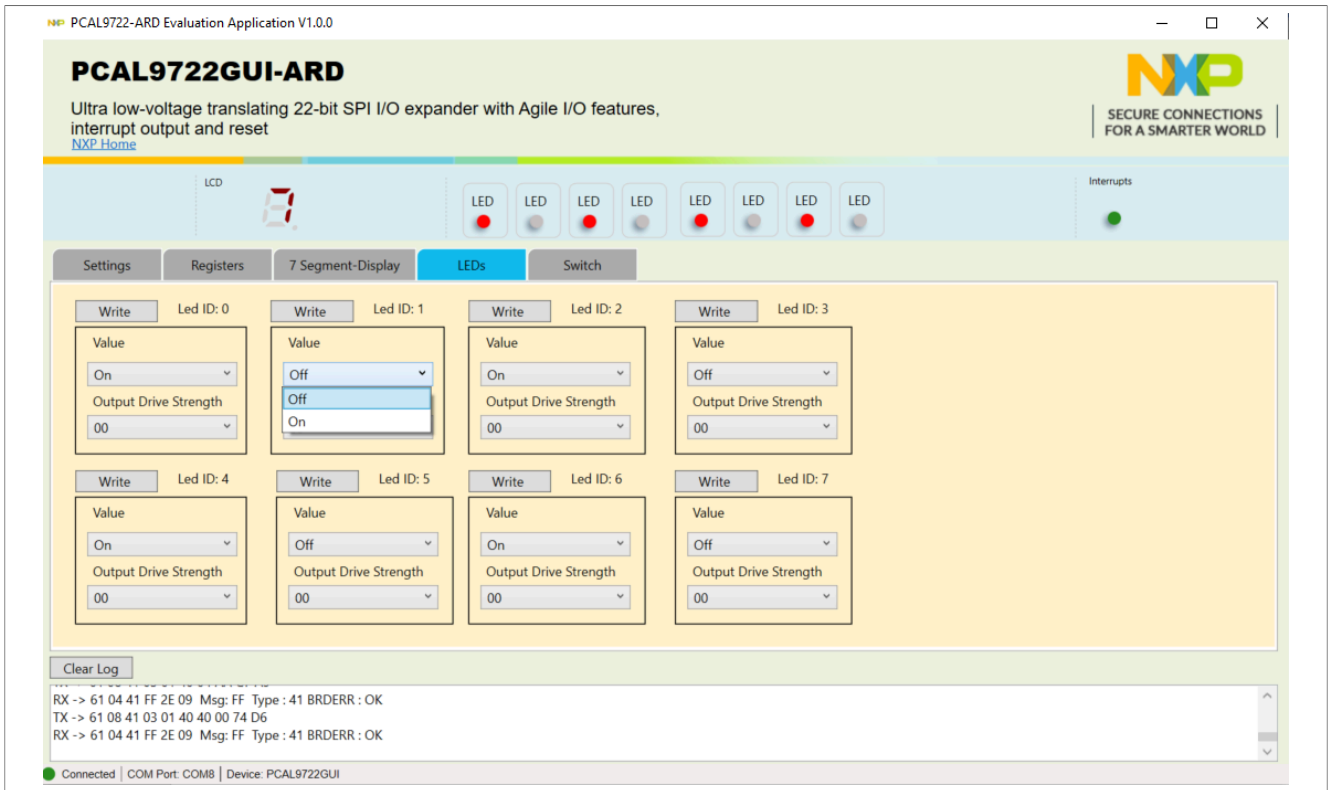

7. Use Switch tab to set input port latch, polarity, pull-up/down settings, and read button to read in key switch statue.

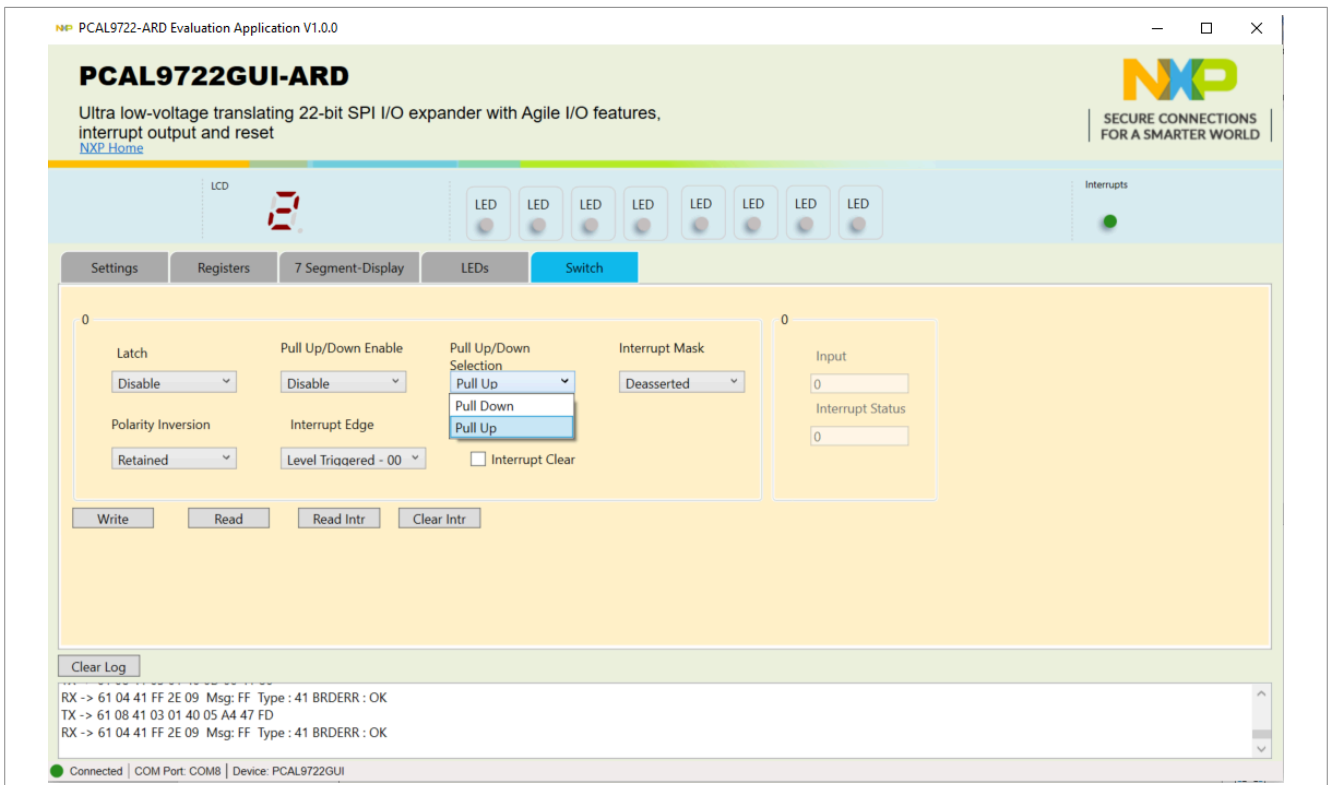

9 Abbreviations

Table 3. Abbreviations

Acronym	Description
ESD	Electro Static Discharge
GUI	Graphical User Interface
SPI-bus	Serial Peripheral Interface bus
IC	Integrated Circuit
LED	Light Emitting Diode
PC	Personal Computer
USB	Universal Serial Bus

10 References

1. *PCAL9722HN, Ultra low-voltage translating 22-bit SPI I/O expander with Agile I/O features, interrupt output and reset; NXP Semiconductors*

11 Revision history

Table 4. Revision history

Document ID	Release date	Description
UM12075 v.1.0	13 June 2024	• Initial version

Legal information

Definitions

Draft — A draft status on a document indicates that the content is still under internal review and subject to formal approval, which may result in modifications or additions. NXP Semiconductors does not give any representations or warranties as to the accuracy or completeness of information included in a draft version of a document and shall have no liability for the consequences of use of such information.

Disclaimers

Limited warranty and liability — Information in this document is believed to be accurate and reliable. However, NXP Semiconductors does not give any representations or warranties, expressed or implied, as to the accuracy or completeness of such information and shall have no liability for the consequences of use of such information. NXP Semiconductors takes no responsibility for the content in this document if provided by an information source outside of NXP Semiconductors.

In no event shall NXP Semiconductors be liable for any indirect, incidental, punitive, special or consequential damages (including - without limitation - lost profits, lost savings, business interruption, costs related to the removal or replacement of any products or rework charges) whether or not such damages are based on tort (including negligence), warranty, breach of contract or any other legal theory.

Notwithstanding any damages that customer might incur for any reason whatsoever, NXP Semiconductors' aggregate and cumulative liability towards customer for the products described herein shall be limited in accordance with the Terms and conditions of commercial sale of NXP Semiconductors.

Right to make changes — NXP Semiconductors reserves the right to make changes to information published in this document, including without limitation specifications and product descriptions, at any time and without notice. This document supersedes and replaces all information supplied prior to the publication hereof.

Suitability for use — NXP Semiconductors products are not designed, authorized or warranted to be suitable for use in life support, life-critical or safety-critical systems or equipment, nor in applications where failure or malfunction of an NXP Semiconductors product can reasonably be expected to result in personal injury, death or severe property or environmental damage. NXP Semiconductors and its suppliers accept no liability for inclusion and/or use of NXP Semiconductors products in such equipment or applications and therefore such inclusion and/or use is at the customer's own risk.

Applications — Applications that are described herein for any of these products are for illustrative purposes only. NXP Semiconductors makes no representation or warranty that such applications will be suitable for the specified use without further testing or modification.

Customers are responsible for the design and operation of their applications and products using NXP Semiconductors products, and NXP Semiconductors accepts no liability for any assistance with applications or customer product design. It is customer's sole responsibility to determine whether the NXP Semiconductors product is suitable and fit for the customer's applications and products planned, as well as for the planned application and use of customer's third party customer(s). Customers should provide appropriate design and operating safeguards to minimize the risks associated with their applications and products.

NXP Semiconductors does not accept any liability related to any default, damage, costs or problem which is based on any weakness or default in the customer's applications or products, or the application or use by customer's third party customer(s). Customer is responsible for doing all necessary testing for the customer's applications and products using NXP Semiconductors products in order to avoid a default of the applications and the products or of the application or use by customer's third party customer(s). NXP does not accept any liability in this respect.

Terms and conditions of commercial sale — NXP Semiconductors products are sold subject to the general terms and conditions of commercial sale, as published at <https://www.nxp.com/profile/terms>, unless otherwise agreed in a valid written individual agreement. In case an individual agreement is concluded only the terms and conditions of the respective agreement shall apply. NXP Semiconductors hereby expressly objects to applying the customer's general terms and conditions with regard to the purchase of NXP Semiconductors products by customer.

Export control — This document as well as the item(s) described herein may be subject to export control regulations. Export might require a prior authorization from competent authorities.

Suitability for use in non-automotive qualified products — Unless this document expressly states that this specific NXP Semiconductors product is automotive qualified, the product is not suitable for automotive use. It is neither qualified nor tested in accordance with automotive testing or application requirements. NXP Semiconductors accepts no liability for inclusion and/or use of non-automotive qualified products in automotive equipment or applications.

In the event that customer uses the product for design-in and use in automotive applications to automotive specifications and standards, customer (a) shall use the product without NXP Semiconductors' warranty of the product for such automotive applications, use and specifications, and (b) whenever customer uses the product for automotive applications beyond NXP Semiconductors' specifications such use shall be solely at customer's own risk, and (c) customer fully indemnifies NXP Semiconductors for any liability, damages or failed product claims resulting from customer design and use of the product for automotive applications beyond NXP Semiconductors' standard warranty and NXP Semiconductors' product specifications.

Translations — A non-English (translated) version of a document, including the legal information in that document, is for reference only. The English version shall prevail in case of any discrepancy between the translated and English versions.

Security — Customer understands that all NXP products may be subject to unidentified vulnerabilities or may support established security standards or specifications with known limitations. Customer is responsible for the design and operation of its applications and products throughout their lifecycles to reduce the effect of these vulnerabilities on customer's applications and products. Customer's responsibility also extends to other open and/or proprietary technologies supported by NXP products for use in customer's applications. NXP accepts no liability for any vulnerability. Customer should regularly check security updates from NXP and follow up appropriately. Customer shall select products with security features that best meet rules, regulations, and standards of the intended application and make the ultimate design decisions regarding its products and is solely responsible for compliance with all legal, regulatory, and security related requirements concerning its products, regardless of any information or support that may be provided by NXP.

NXP has a Product Security Incident Response Team (PSIRT) (reachable at PSIRT@nxp.com) that manages the investigation, reporting, and solution release to security vulnerabilities of NXP products.

NXP B.V. — NXP B.V. is not an operating company and it does not distribute or sell products.

Trademarks

Notice: All referenced brands, product names, service names, and trademarks are the property of their respective owners.

NXP — wordmark and logo are trademarks of NXP B.V.

Tables

Tab. 1.	PCAL9722HN-ARD EV board main components	9	Tab. 3.	Abbreviations	15
Tab. 2.	Jumper settings	9	Tab. 4.	Revision history	17

Figures

Fig. 1. PCAL9722HN-ARD evaluation board7 Fig. 2. PCAL9722HN-ARD evaluation board connecting to the LPC55S69-EVK MCU board 8

Contents

1	Introduction	3
2	Features	4
3	Finding kit resources and information on the NXP web site	5
4	Getting ready	6
4.1	Kit contents	6
4.2	Additional hardware	6
4.3	Assumptions	6
4.4	Static handling requirements	6
4.5	Minimum system requirements	6
4.6	Power requirements	6
5	Hardware installation	7
5.1	PCAL9722HN-ARD EV board and LPC55S69-EVK MCU board connection	7
6	Hardware description	9
7	Schematic	10
8	PCAL9722HN demo GUI	11
8.1	Install PCAL9722HN-ARD Demo GUI	11
8.2	Run PCAL9722 Demo GUI on Windows 7, 8, and 10 PC	11
9	Abbreviations	15
10	References	16
11	Revision history	17
	Legal information	18

Please be aware that important notices concerning this document and the product(s) described herein, have been included in section 'Legal information'.
