

Contents

ision



Revisions			
Rev	Description	Date	Approved
X1	Initial	May 15, 2012	
A	Release	June 29, 2012	Wang Peng Michael Norman
A1	Revise J7, J8, J9, JP1. Remove U5.	September 3, 2012	
A2	Rename J10 for 1x6 connector	September 4, 2012	
A3	Add R27, R28 with DNP Populate J4, J5	September 6, 2012	
A4	Populate R27, R28 and DNP J4, J5	September 6, 2012	
B	Release	September 18, 2012	
B1	Label J1 as SWD, release	September 20, 2012	Wang Peng Michael Norman

		<b>Microcontroller Solutions Group</b>	
		6501 William Cannon Drive West Austin, TX 78735-8598	
This document contains information proprietary to Freescale Semiconductor and shall not be used for engineering design, procurement or manufacture in whole or in part without the express written permission of Freescale Semiconductor.			
Designer: Wang Peng		Drawing Title: <b>FRDM-KL05Z</b>	
Drawn by: Qiao Jun		Page Title: <b>Table of Contents/Revisions</b>	
Approved: Michael Norman	Size C	Document Number SCH-27626 PDF-SPF-27626	Rev B1
Date: Friday, September 21, 2012		Sheet 1 of 5	



		
ICAP Classification: FCP: _____ FLUQ: X PUB: _____		
Drawing Title: <b>FRDM-KL05Z</b>		
Page Title: <b>NOTES</b>		
Size C	Document Number SCH-27626 PDF-SPF-27626	Rev B1
Date: Friday, September 21, 2012	Sheet 2	of 5

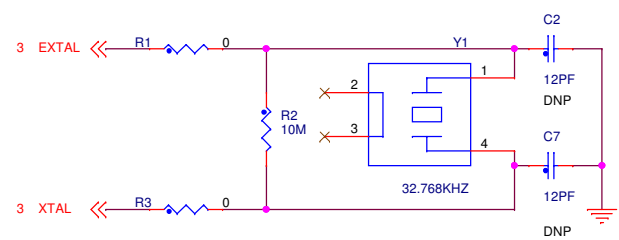
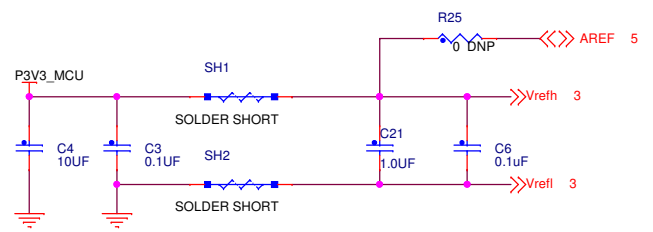
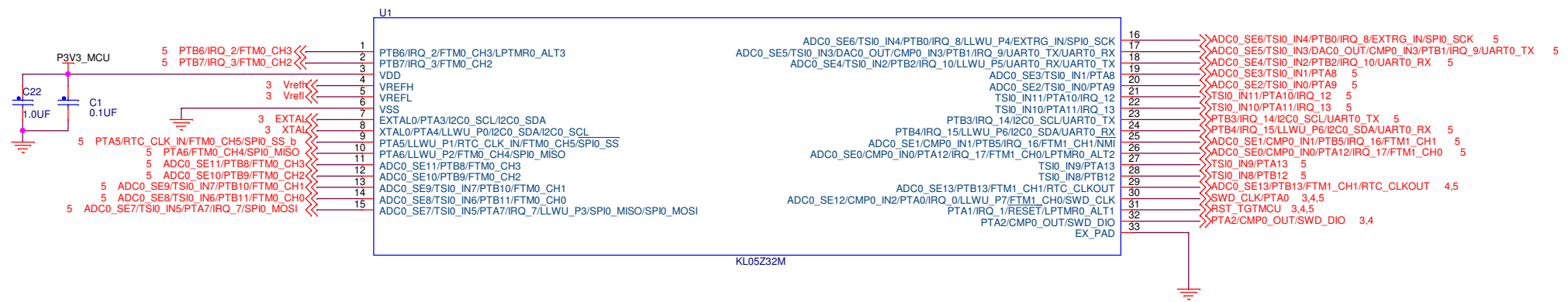
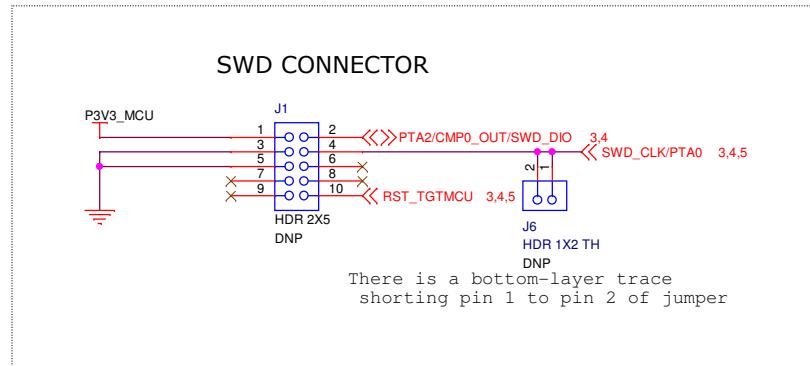

**freescalse™**  
semiconductor

ICAP Classification: FCP: \_\_\_\_\_ FIUO: X PUBI: \_\_\_\_\_  
Drawing Title:  
**FRDM-KL05Z**  
Page Title:  
**MCU**

Size B	Document Number <b>SCH-27626 PDF-SPF-27626</b>	Rev B1
--------	---	--------

Date: Friday, September 21, 2012 Sheet 3 of 5



**TO LEVERAGE OPENSDA INTERFACE IN YOUR DESIGN**  
 PLEASE PROVIDE +3.3VDC REGULATION TO P3V3\_USBSSER FROM P3V0\_USBSSER VOLTAGE RAIL  
 ALSO PROVIDE +3.3VDC REGULATION TO P3V3 FROM TARGET MCU VOLTAGE RAIL

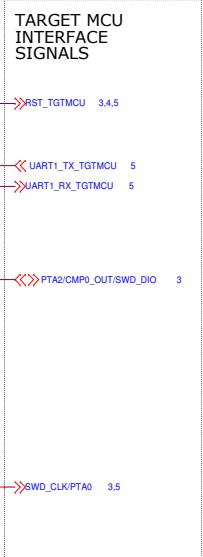
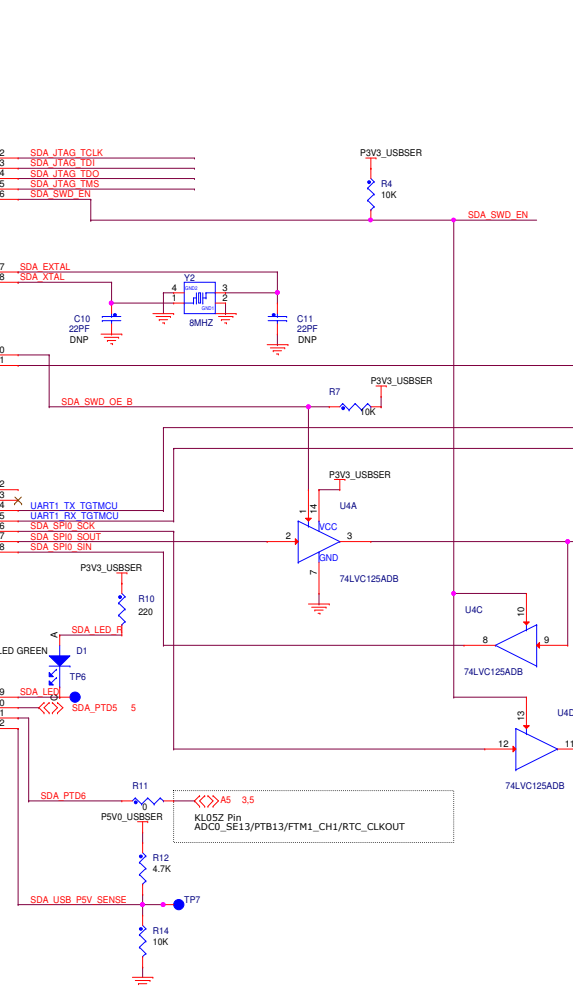
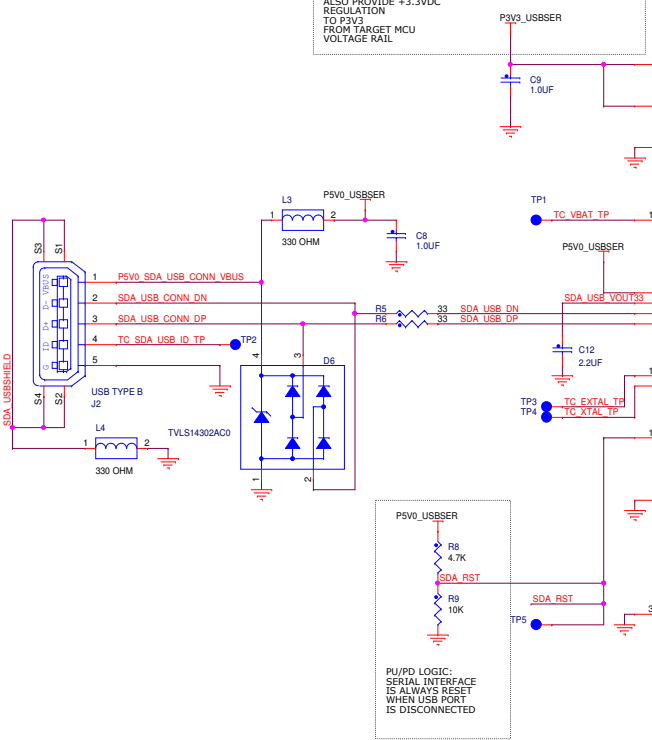

**OPEN-SDA INTERFACE**

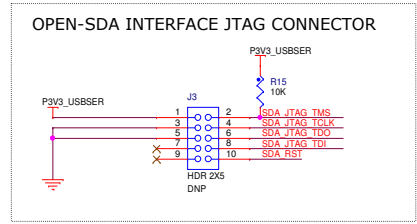
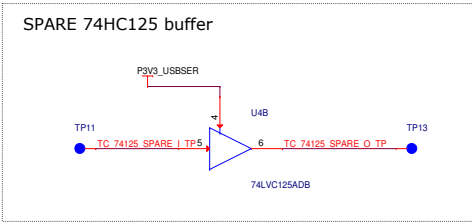
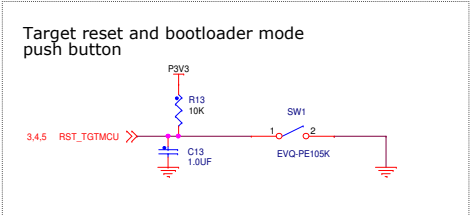

ICAP Classification: FCP: FLUQ: PUBL: X  
 Drawing Title: **FRDM-KL05Z**  
 Page Title: **OPEN-SDA interface**  
 Size C Document Number SCH-27626 | PDF: SPF-27626 Rev B1  
 Date: Friday, September 21, 2012 Sheet 4 of 5

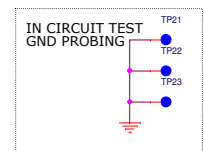
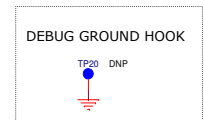
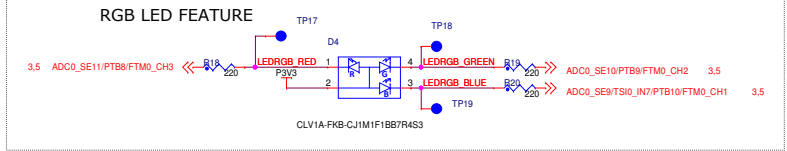
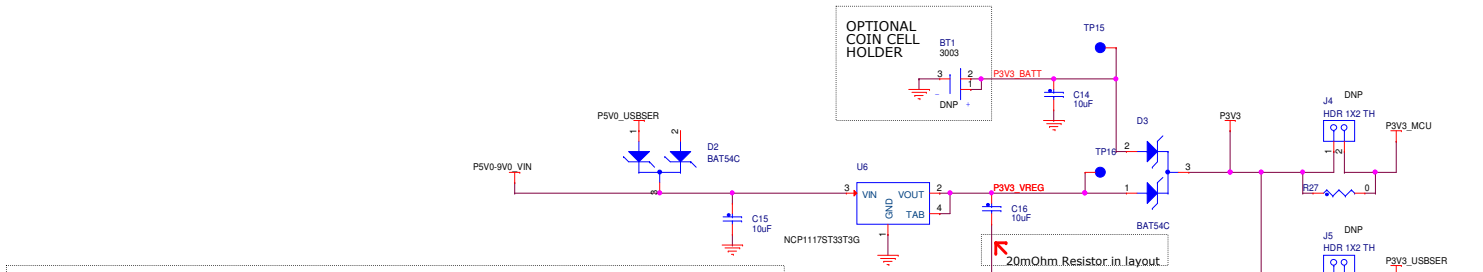

I2C INERTIAL SENSOR

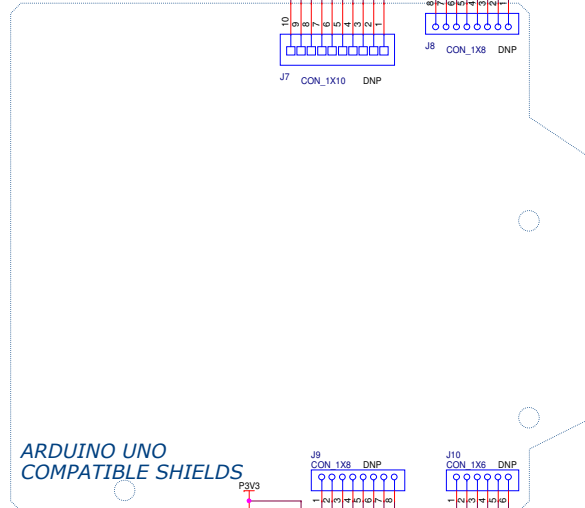
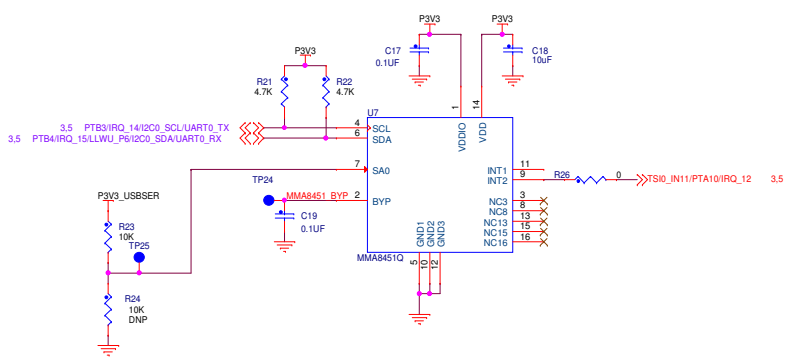

TOUCH ELECTRODES

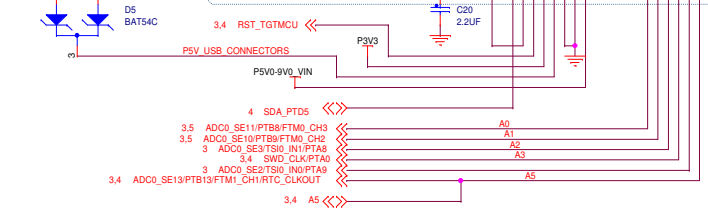

**freescale™**  
semiconductor

ICAP Classification: FCP: FLUC: PUBL: X  
 Drawing Title: **FRDM-KL05Z**  
 Page Title: **ARDUINO SHIELDS & PWR SUPPLY**

Size C	Document Number SCH-27626   PDF: SPF-27626	Rev B1
Date: Friday, September 21, 2012	Sheet 5 of 5	