



<b>Contents</b>	
List	
am	
5	MCU Debug 2
6	MCU Power 1
7	MCU Power 2
8	USB OSJTAG JTAG
9	CAN UART RS485 RS232
10	I/O BUTTONS LEDs ACCEL. TWRPI
11	Clock
12	Elevator Connectors

Revision	Date	Revision History Description	Approved
X1	09/26/2011	Initial Draft/A070 Release	Vikas
X2	09/27/2011	1. Power Flow updated. 2. J49 Added in the design.	Vikas
X3	09/29/2011	Power Flow Updated	Vikas
X4	09/30/2011	0 E added in the Power Flow	Vikas
X5	09/29/2011	Power Flow Updated	Vikas
X6	04.10.2011	Power Flow, unused pins, move parts between sheets	Jiri
X7	06.10.2011	UART, RS485 pin numbers , LED0<->LED1	Jiri
X8	10/07/2011	Capacitors for 1.2 V is changed, All headers 2X3 changed to through hole except J28	Sudhasha
X9	10/10/2011	VSSSYN net connected to 40 MHz crystal and 0 ohms added to VSSSYN to GND	Sudhasha
X10	10/12/2011	VSSA Ground is changed to AGND for TWRPI connector	Sudhasha
X11	10/18/2011	Nexus pin connection added, U3 IC is updated with new part	Sudhasha
X12	10/21/2011	Schematics back annotated. VRH and VRL net added to J14A	Sudhasha
X13	10/27/2011	Both 256 BGA and 208 BGA package added in the schematics	Sudhasha
X14	10/31/2011	Decaps added to the Nexus power pin VDDN(256 BGA)	Sudhasha
X15	31.10.2011	Descriptions and general appearance	Jiri
A	11/2/2011	Prototype Release	Sudhasha
B	12.03.2012	Four LEDs, VddA, GNDA, and /RESET to elevator, RS485 pull resistors, References, AD and DA filter	Jiri Alberto

		<b>Microcontroller Solutions Group</b> 6501 William Cannon Drive West Austin, TX 78735-8598	
		<small>This document contains information proprietary to Freescale Semiconductor and shall not be used for engineering design, procurement or manufacture in whole or in part without the express written permission of Freescale Semiconductor.</small>	
Designer: Kotzian Jiri	Drawing Title: <b>TWR-PXN20</b>		
Drawn by: Sudhasha, Jiri, Alberto	Page Title: <b>Table of Contents/Revisions</b>		
Approved: Ruiz Jose/Kotzian Jiri	Size C	Document Number SCH-27309 PDF: SPF-27309	Rev B
Date: Wednesday, March 14, 2012 Sheet 1 of 12			

Net	Description
GND	Digital Ground
P5V_USB	Module Power Supply from USB (5V)
P5V_SW	OSBDM Power (5V)
P5V_TRG_USB	Module Power Supply from USB (5V)
P5V_ELEV	Main 5V (Elevator or USB Supply)
P3V3	Main 3.3V (Elevator or On Board Voltage Regulator Supply)
VRC	MCU Voltage Regulator Control Voltage (3.3V default / optional 5V)
VRCSEL	MCU Voltage Regulator Select (0V default / optional 5V)
VRCCTL	MCU Voltage Regulator Control Output
1V2	MCU Internal Logic Power (1.2V)
P3V3_MCU	MCU External I/O Power (3.3V)
VDD	MCU I/O Power (3.3V)
VDDN	MCU NEXUS Power (3.3V)
VDDMLB	MCU Media Local Bus Power (3.3V default / optional 2.5V)
VDDE1-4	MCU External I/O Power (3.3V default / optional 5V)
VSSYNC	MCU Clock Synthesizer Ground
VDDSYN	MCU Clock Synthesizer Power (3.3V)
AGND	MCU Analog Ground
VDDA	MCU Analog Power (3.3V default / optional 5V)
VRL	MCU Analog Low Voltage Reference
VRH	MCU Analog High Voltage Reference (3.3V default / optional 5V)

	
ICAP Classification: FCP: _____ FIUC: X PUB: _____	
Drawing Title: <b>TWR-PXN20</b>	
Page Title: <b>Notes</b>	
Size C	Document Number SCH-27309 PDF: SPF-27309
Date: Monday, March 12, 2012	Sheet 2 of 12

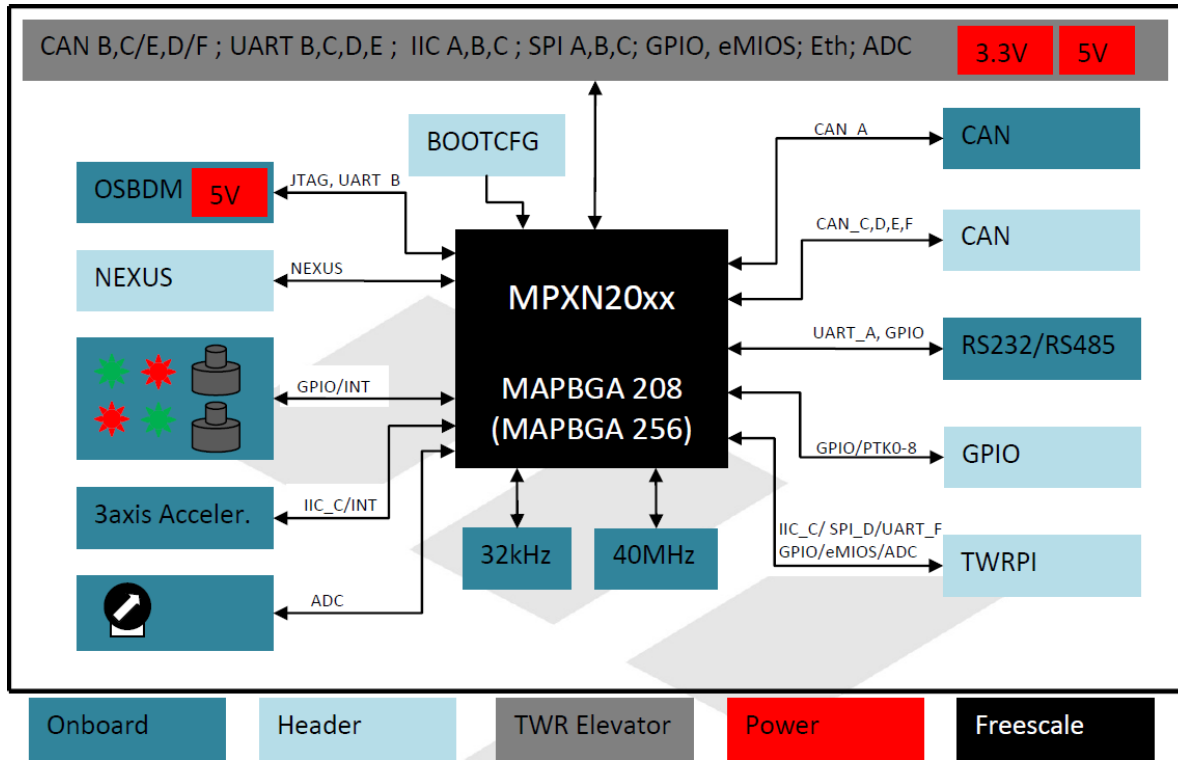

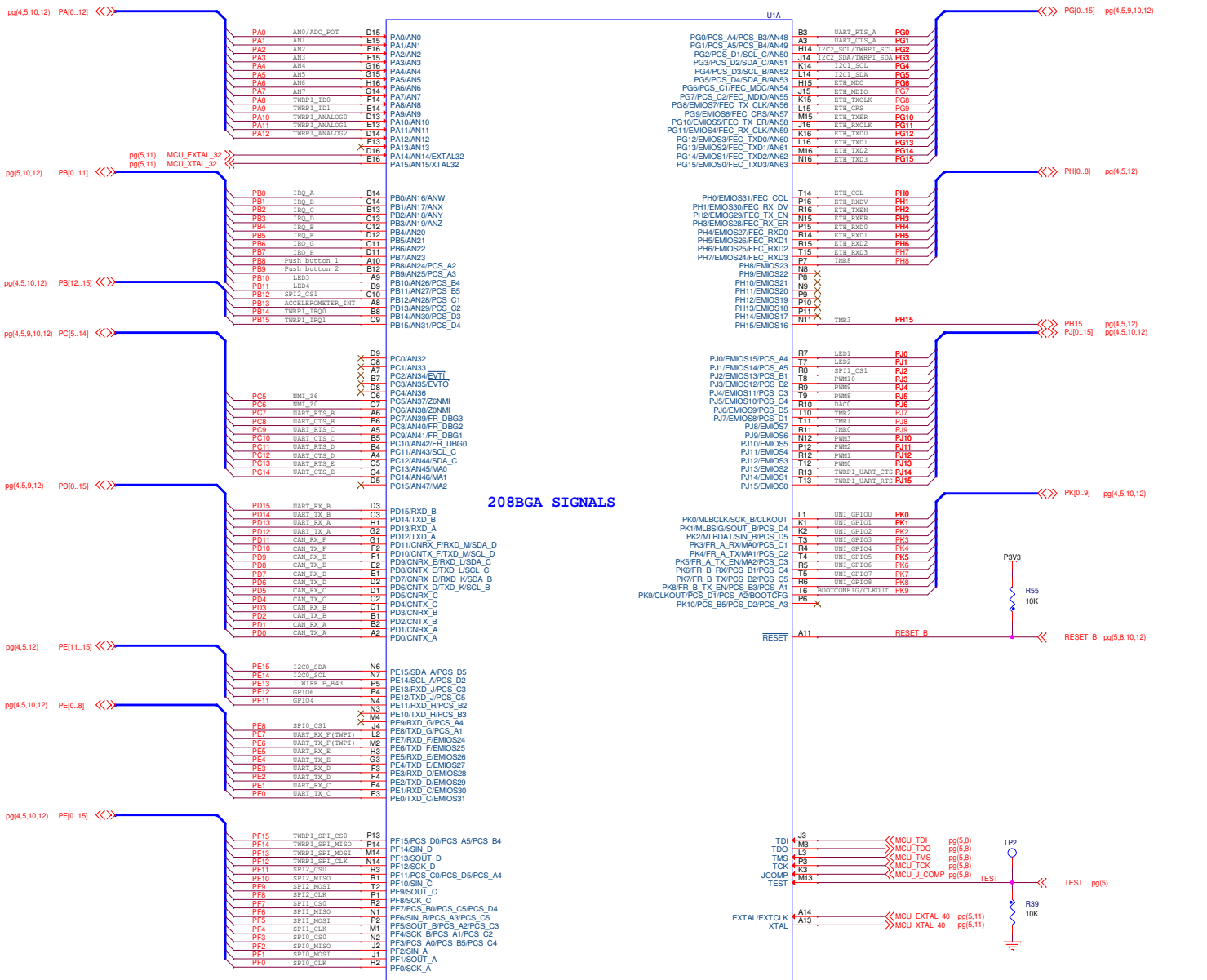

208BGA SIGNALS

Intersheet References

pg(4.5,10,12)	PB(0..9)	<<>
pg(4.5,10,12)	PE(0..8)	<<>
pg(4.5,10,12)	PA(0..12)	<<>
pg(4.5,10,12)	PB(12..15)	<<>
pg(4.5,9,10,12)	PC(5..14)	<<>
pg(4.5,12)	PE(11..15)	<<>
pg(4.5,10,12)	PF(0..15)	<<>
pg(4.5,12)	PH(0..8)	<<>
pg(4.5,10,12)	PJ(0..15)	<<>
pg(4.5,10,12)	PQ(0..15)	<<>
pg(4.5,12)	PH(0..8)	<<>
pg(4.5,10,12)	PJ(0..15)	<<>
pg(4.5,12)	PK(0..9)	<<>
pg(4.5,12)	PH(15)	<<>

**freescale**  
semiconductor

ICAP Classification: FCP: FIUC: X PUB: \_\_\_\_\_  
Drawing Title: **TWR-PXN20**

Page Title: **MCU\_Debug**

Size C Document Number SCH-27309 PDF: SPF-27309 Rev B

Date: Wednesday, March 14, 2012 Sheet 4 of 12

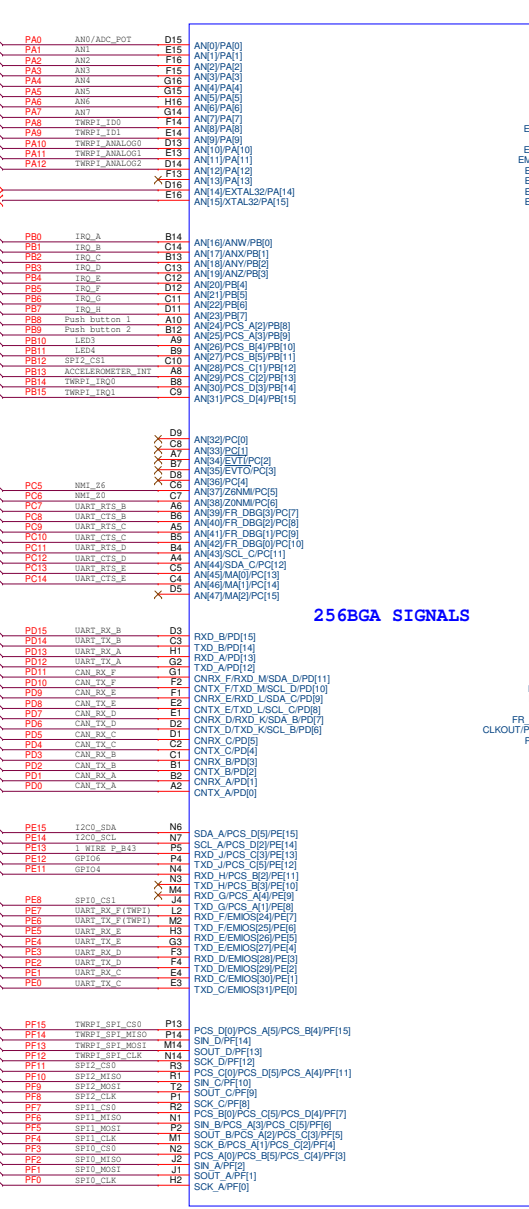
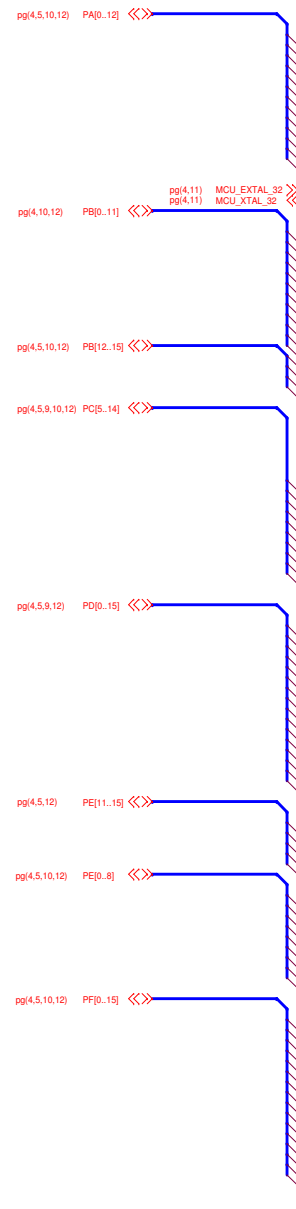

256BGA SIGNALS

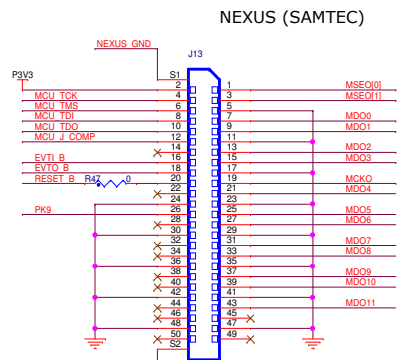
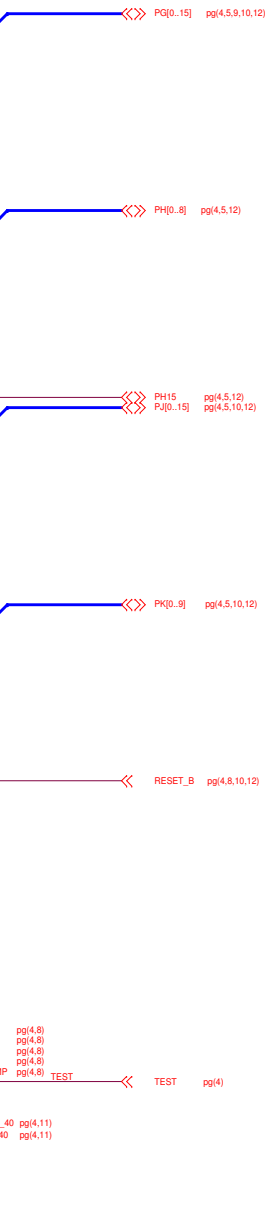
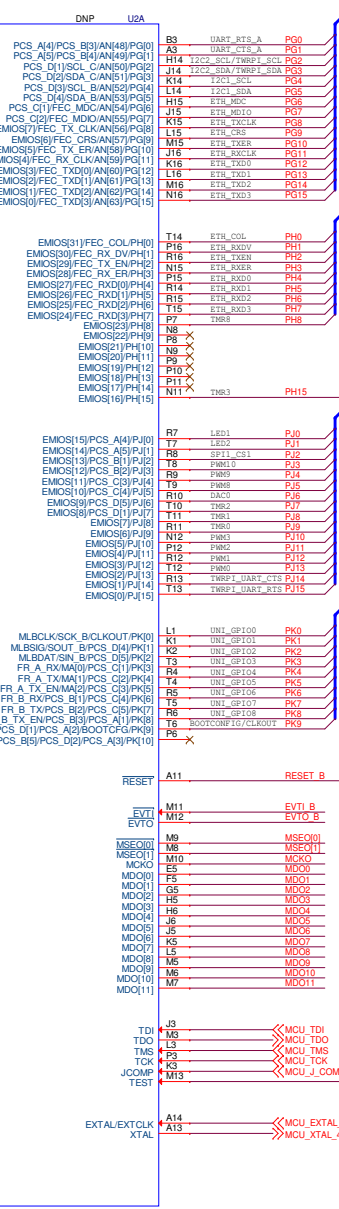

Intersheet References

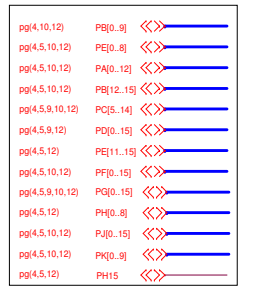

PPXN2020V1J15R

**freescale**  
semiconductor

ICAP Classification: FCP: FIUC: X PUB: \_\_\_\_\_  
Drawing Title: **TWR-PXN20**

Page Title: **MCU\_Debug**

Size C Document Number SCH-27309 PDF: SPF-27309 Rev B

Date: Wednesday, March 14, 2012 Sheet 5 of 12

Analog Voltage "VDDA" Generation

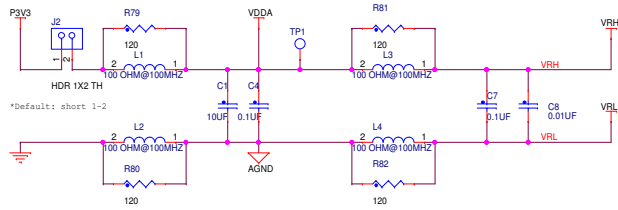

Supply Voltage for MCU

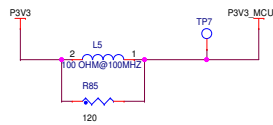

Digital Ground

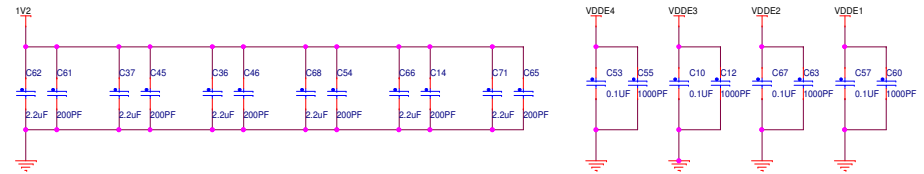
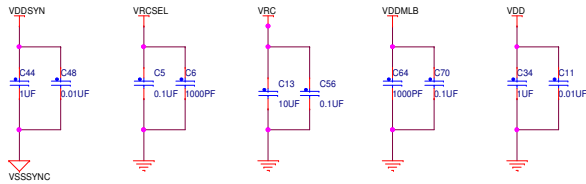
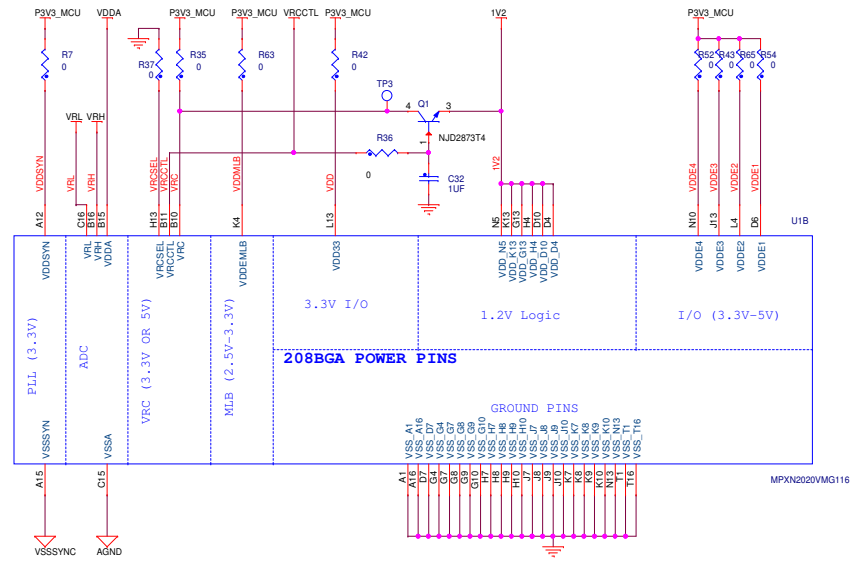
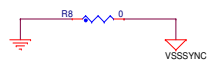









### UART B

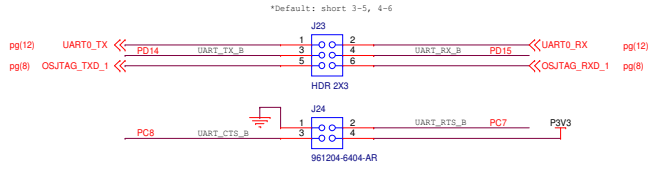

### UART A

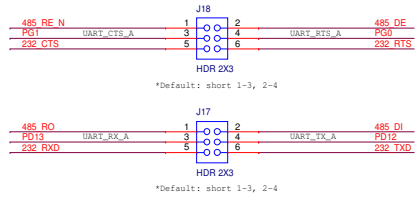

### UART A / RS485

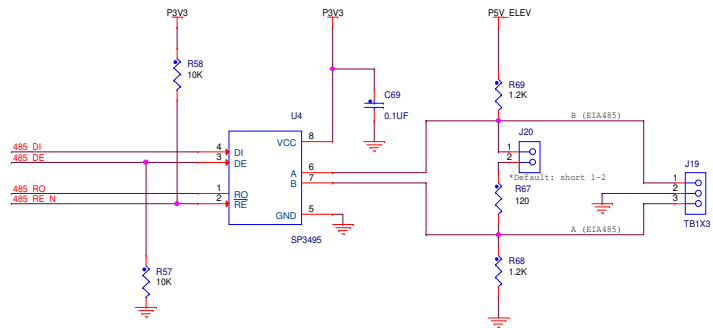

### UART A / RS232

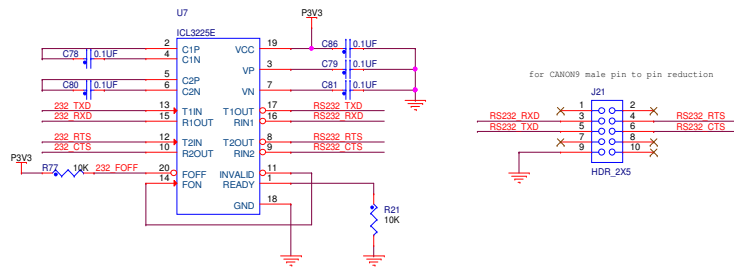

### CAN C, CAN E

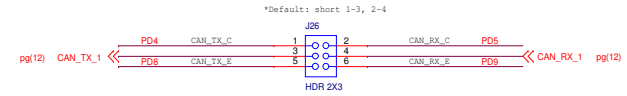

### CAN D, CAN F

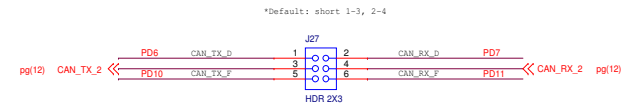

### CAN A / CAN

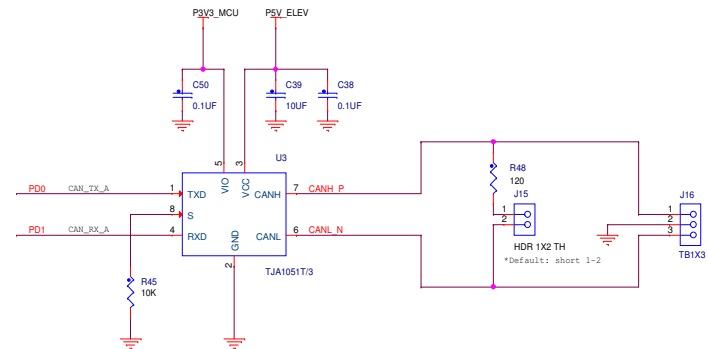

### Intersheet References

pg(4.5,10,12)	PB[12..15]	<<>>
pg(4.5,10,12)	PA[0..12]	<<>>
pg(4.5,10,12)	PB[0..9]	<<>>
pg(4.5,10,12)	PC[5..14]	<<>>
pg(4.5,12)	PD[0..15]	<<>>
pg(4.5,10,12)	PE[0..8]	<<>>
pg(4.5,10,12)	PF[0..15]	<<>>
pg(4.5,12)	PG[0..15]	<<>>
pg(4.5,12)	PH[0..8]	<<>>
pg(4.5,10,12)	PJ[0..15]	<<>>
pg(4.5,10,12)	PK[0..9]	<<>>
pg(4.5,12)	PH15	<<>>
pg(4.5,12)	PE[11..15]	<<>>

ICAP Classification: FCP: FIUC: X PUB: \_\_\_\_\_  
 Drawing Title: **TWR-PXN20**  
 Page Title: **CAN\_UART\_RS485\_RS232**  
 Size C Document Number SCH-27309 PDF: SPF-27309 Rev B  
 Date: Wednesday, March 14, 2012 Sheet 9 of 12

### Buttons / LEDs

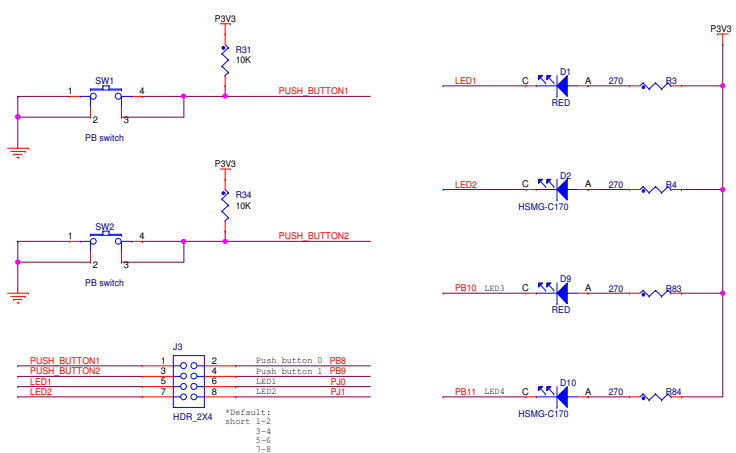

### General Purpose TWRPI Socket\_Left-side

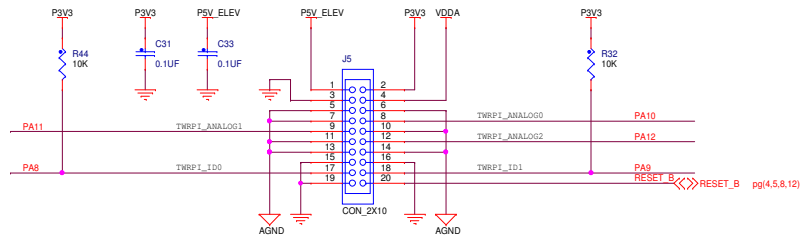

### General Purpose TWRPI Socket\_Right-side

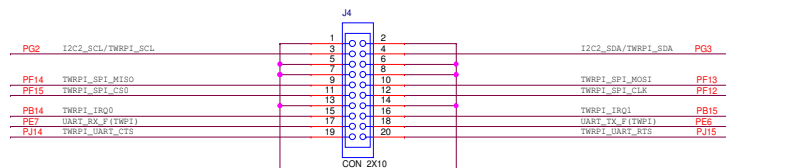

### Accelerometer

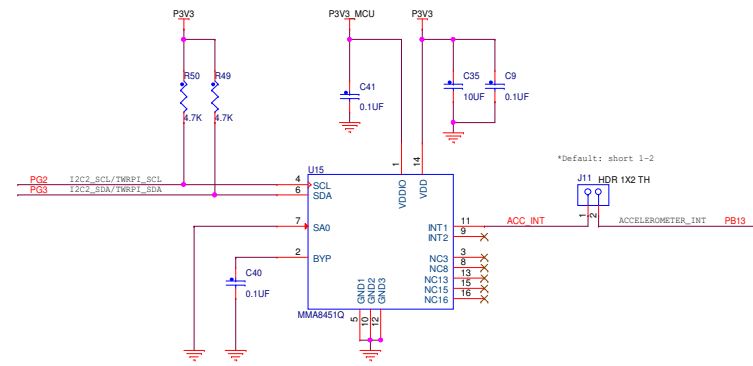

### Potentiometer

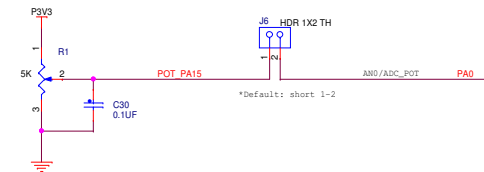

### Universal Header

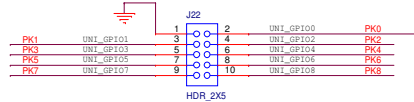

### Boot Config

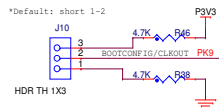

### NMI

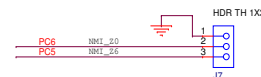

### DAC filter PWM

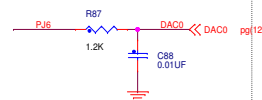

### Intersheet References

pg(4.5.12)	PB[12..15]	<<>>
pg(4.5.12)	PE[0..8]	<<>>
pg(4.5.12)	PA[0..12]	<<>>
pg(4.5.12)	PB[0..11]	<<>>
pg(4.5.9.12)	PC[5..14]	<<>>
pg(4.5.9.12)	PD[0..15]	<<>>
pg(4.5.12)	PE[11..15]	<<>>
pg(4.5.12)	PF[0..15]	<<>>
pg(4.5.9.12)	PG[0..15]	<<>>
pg(4.5.12)	PH[0..8]	<<>>
pg(4.5.12)	PJ[0..15]	<<>>
pg(4.5.12)	PK[0..9]	<<>>
pg(4.5.12)	PH15	<<>>

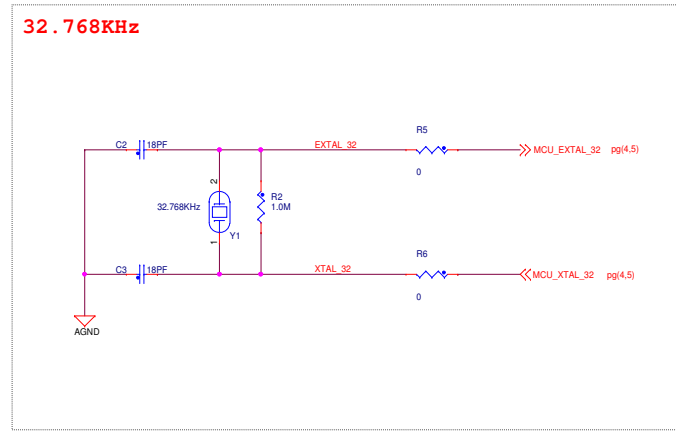
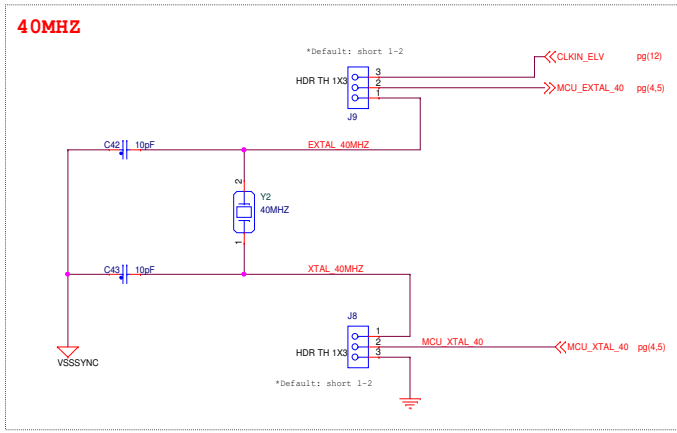

**Intersheet References**

pg(4.5,10,12)	PB[12..15]	<<>
pg(4.5,10,12)	PA[0..12]	<<>
pg(4.5,10,12)	PB[0..9]	<<>
pg(4.5,9,10,12)	PC[5..14]	<<>
pg(4.5,9,12)	PD[0..15]	<<>
pg(4.5,10,12)	PE[0..8]	<<>
pg(4.5,10,12)	PF[0..15]	<<>
pg(4.5,9,10,12)	PG[0..15]	<<>
pg(4.5,12)	PH[0..8]	<<>
pg(4.5,10,12)	PJ[0..15]	<<>
pg(4.5,10,12)	PK[0..9]	<<>
pg(4.5,12)	PH15	<<>
pg(4.5,12)	PE[11..15]	<<>

ICAP Classification: FCP: FIUC: X PUB: \_\_\_\_\_

Drawing Title: **TWR-PXN20**

Page Title: **Clock**

Size C	Document Number SCH-27309 PDF: SPF-27309	Rev B
Date: Wednesday, March 14, 2012	Sheet 11 of 12	

