

# Compact Integrated Antennas

Designs and Applications for the MC1321x, MC1322x,  
MC1323x, and MKW40/30/20

## 1 Introduction

With the introduction of many applications into the 2.4 GHz band for commercial and consumer use, Antenna design has become a stumbling point for many customers. Moving energy across a substrate by use of an RF signal is very different than moving a low frequency voltage across the same substrate. Therefore, designers who lack RF expertise can avoid pitfalls by simply following *good* RF practices when doing a board layout for 802.15.4 and Bluetooth low energy applications. The design and layout of antennas is an extension of that practice. This application note will provide some of that basic insight on board layout and antenna design to improve our customers' first pass success.

Antenna design is a function of frequency, application, board area, range, and costs. Whether your application requires the absolute minimum costs or minimization of board area or maximum range, it is important to understand the critical parameters so that the proper trade-offs can be chosen. Some of the parameters necessary in selecting the correct antenna are: antenna tuning, matching, gain/loss, and required radiation pattern.

### Contents

1. Introduction	1
2. Antenna Terms	2
3. Basic Antenna Theory	3
4. Impedance Matching	4
5. Antennas	7
6. Miniaturization Trade-offs	10
7. Potential Issues	11
8. Recommended Antenna Designs	11
9. Design Examples	12

This note is not an exhaustive inquiry into antenna design. It is instead, focused toward helping our customers understand enough board layout and antenna basics to aid in selecting the correct antenna type for their application as well as avoiding the typical layout mistakes that cause performance issues that lead to delays. Additionally, several popular antennas are presented as possible solutions for some of the 802.15.4 and Bluetooth low energy applications.

## 2 Antenna Terms

The following table lists the antenna terms.

**Table 1. Antenna terms**

Term	Description
Antenna Gain	A mathematical measure of an antenna radiation pattern compared to a reference antenna such as a dipole or an isotropic radiator. The gain is usually measured in dBs relative to a dipole or dBi relative to an ideal isotropic. In any given direction, a negative gain means that the antenna radiates less than the reference antenna and a positive number means that the antenna radiates more than the reference antenna.
Decibel (dB)	A logarithmic scale that represents power gain or loss in an RF circuit. 3 dB represents a doubling of power, -3 dB is half the power and -6 dB represents half the voltage or current, but a quarter of the power.
(dBi)	Application of the logarithmic scale to Antenna gain that is relative to an ideal isotropic antenna.
Radiation Resistance	The real part of an antenna's impedance that is associated with radiated power.
Antenna Efficiency	It is the ratio of the power radiated to the power delivered to the antenna input. Hence, an antenna with 50% efficiency has a ratio of 0.5 or -3 dB. Total efficiency includes antenna efficiency and also accounts for mismatch losses.
Transmission Lines	A physical means to transport an RF signal from one point to another, which is defined by its physical constraints to match the characteristic impedance of the system. Most common systems use 50 Ohms characteristic impedance.
Microstrip	A type of electrical <i>transmission line</i> that can be fabricated using <i>printed circuit board</i> technology, and is used to convey <i>microwave</i> -frequency signals. It consists of a conducting strip separated from a <i>ground plane</i> by a <i>dielectric</i> layer known as the substrate.
Stripline	A type of electrical <i>transmission line</i> that can be fabricated using <i>printed circuit board</i> technology, and is used to convey <i>microwave</i> -frequency signals. It consists of a flat strip of metal that is sandwiched between two <i>parallel ground planes</i> . The insulating material of the <i>substrate</i> forms a <i>dielectric</i> . The width of the strip, the thickness of the substrate, and the <i>relative permittivity</i> of the substrate determine the <i>characteristic impedance</i> of the strip, which is a <i>transmission line</i> .
Coplanar Waveguide (CPW)	<i>Classic</i> coplanar waveguide (CPW) is formed from a conductor separated from a pair of ground planes, all on the same plane, atop a dielectric medium. In the ideal case, the thickness of the dielectric is infinite. A variant of coplanar waveguide is formed when a ground plane is located beneath the transmission line against the substrate.
Characteristic Impedance	Usually written $Z_0$ , is the ratio of the amplitudes of voltage and current of a single wave propagating along a transmission line travelling in one direction.
Mismatch Loss	The amount of power expressed in <i>decibels</i> that will not be available on the output due to impedance mismatches and <i>signal reflections</i> .
Resistive Loss	The component of Power loss, expressed in decibels, due to ohmic voltage reduction as a wave travels along a transmission line.

### 3 Basic Antenna Theory

A common method to evaluate an antenna is to view its antenna gain pattern. An antenna's gain pattern is a measure of directionality of the antenna. A perfect theoretical omni-directional antenna radiates equally in all directions and its field would look like a perfect sphere. However, practical manufacturable antennas cannot be made to radiate equally in all directions. Therefore, all practical antennas will have some gain. The higher the gain the more directional is the antenna. Large distance fixed position applications actually require a highly directional antenna. Whereas, a general purpose local area network will usually require an antenna that is omni-directional.

Theoretically, any metallic structure can be used as an antenna. However, some structures are more efficient in radiating and receiving RF power than others. Transmission lines are used to convey the signal between the radio and the antenna with minimum loss due to resistive, mismatch and radiative losses as possible. The following examples explain these concepts.

Transmission lines take on a variety of shapes such as microstrip, coplanar waveguide, stripline, coaxial lines, etc.. For 802.15.4 and Bluetooth low energy applications built on FR4 substrates, the methods of transmission lines typically take the form of microstrip, or coplanar waveguide (CPW). These two structures are defined by the dielectric constant of the board material, the line width, the board thickness between the line and the ground and additionally for CPW, the gap between the line and the top edge ground plane. These parameters are used to define the characteristic impedance of the transmission line that is used to convey the RF energy between the radio and the antenna.

Typically, the RF ports from the 802.15.4 radios and Bluetooth low energy applications are differential or balanced. These ports RF impedances at the radio are in the range of 100 Ohms. Freescale's applications typically use a balun to transform the balanced signals to a single ended output with a characteristic impedance of 50 ohms. Therefore, Freescale recommends an antenna with a 50 ohm feed.

The typical network for an 802.15.4 radio and Bluetooth low energy application includes a matching network between the radio ports (typically differential RF ports) and the antenna. To minimize loss and simplify the matching, a balun is typically employed with Freescale's application boards with component matching between the balun and the radio on the differential side of the balun. Then, to suppress any 2nd harmonic spurious in the spectrum, a 2nd harmonic trap is placed between the balun and the antenna on the single ended side of the balun. The transmission lines on the differential side of the Balun are usually high impedance but are short in length and therefore, are sized more for manufacturing optimization than for RF performance with little impact to performance. The balun is essentially a transformer that can be chosen at various ratios of 1:1, 2:1 or 4:1 for optimum matching. The 2nd harmonic trap consists of a high-Q capacitor for minimum loss, which is used to series resonate with its self inductance along with the board via inductance at the 2nd harmonic or approximately 4900 MHz. This resonance presents an RF short at the second harmonic shunting most of the unwanted signal to ground. The trap capacitor increases the loss at the fundamental frequency. This fundamental frequency loss can be minimized in two ways: First, by adding inductance to the self inductance of the capacitor. This allows the capacitor to resonate using a lower value capacitor. The lower the value of the capacitance, the lower the impact to the fundamental frequency loss. Second, by creating an open *tank* circuit that resonates at the fundamental frequency (2445 MHz). This is accomplished by placing an inductor in parallel to the shunt trap capacitor that together has a 2445 MHz open circuit resonance.

The antenna structure should be a reasonable size compared to the wavelength of the RF field. A natural size is a half wavelength. A half wavelength corresponds to approximately 6 cm (in air) in the 2.4 GHz ISM band. This size is effective because when it is fed with RF power at the center point, the structure is resonant at the half wave frequency. Reducing the size below the natural resonant length can cause low efficiency. Not all structures make an efficient antenna.

Numerous structures have been devised that provide good efficiency and a good impedance match, but most of these are derived from a few basic structures. A short description of the basic antennas recommended by Freescale and some advice on how to implement these with success is provided later in this note. It is beyond the scope of this note to include complicated formulas concerning antenna theory. This note is intended to provide basic information about antennas, which will allow users to achieve reasonable performance with a few sample antennas.

Users interested in optimizing antenna performance by complex calculations and antenna simulations should consult the abundant and widely available literature concerning antenna theory and design. Usually, copying a Freescale existing design should ensure reasonable performance. However, many factors affect performance such as antenna type, matching impedance, antenna gain (directionality), substrate thickness, substrate dielectric constant, and antenna efficiency.

## 4 Impedance Matching

### 4.1 Radio to the Antenna

The best chance for customer first pass success is to copy Freescale's reference designs verbatim. However, some applications require a substrate with a different layer count or different thickness than what is recommended. Sometimes space is not available for a printed antenna or components from application circuitry may be adjacent to the RF area. Often times, the product plastic encapsulation will interfere with performance.

There are important aspects of the board layout that must be followed if the customer is to achieve maximum performance from the radio. That includes making sure that no metal is under or around the antenna that is not called out in Freescale reference designs. In addition, an often made mistake is for customers to run traces under the RF section on layer 2 ground, thereby cutting the ground reference plane that the RF traces require to maintain designed impedance. All of these errors cause the radio to be loaded or the return loss to be high. If that happens, the signal that is to be transported to the antenna for radiation will instead be reflected back into the radio. Therefore, it is just as critical that attention is paid to the matching network layout as to the antenna design.

A good practice is to review all components in the RF section of a layout and remove all excess metal. That is, metal that *fills in* around components and around the radio IC pins. In addition, avoid routing of lines near or parallel to RF transmission lines or RF bias lines. RF signals will couple to these pieces of metal, which are usually connected to ground and therefore will distort the signal causing excessive VSWR. As mentioned before, avoid any routing on the ground layer that would result in cutting the ground under the RF line. Maintaining a continuous ground under an RF trace is critical to maintaining the characteristic impedance of that line. The recommended stackup is as follows: Beginning at the top: Top - RF routing of transmission lines. L2 - Ground, L3 - DC routing, Bottom - DC routing.

Although there are antennas that are capable of matching to differential impedance, this application note is restricted to single ended or unbalanced matching. This is further restricted to antennas with a feed impedance of 50 Ohms. The goal is to have an antenna on the Printed Circuit Board (PCB) that has as its matching impedance  $50 +j0$  Ohms. In this way, the antenna will act as a 50 Ohm load to the output of the radio that feeds it. Therefore, the matching, when properly done, will load the radio's differential ports to obtain maximum power, minimum RX sensitivity, and minimum distortion of the radio signal while moving the signal with minimum loss between the antenna and the radio.

Antennas can be heavily loaded (increased VSWR) when placed in close proximity to ground. The close proximity to ground affects radiation resistance, which then can cause the match to deviate considerably from 50 Ohms, which in-turn translates to a poor match further down the matching network to the radios' output.

During the layout of the board, provisions need to be made to allow for measurement of the antenna VSWR. Even though a user may copy the antenna shape exactly as prescribed by Freescale, the material parameters may differ enough to cause the antenna to shift in frequency. If that occurs, it may not matter that the part is tuned for maximum power as most of it will be reflected back in to the radio if the VSWR is high. To avoid that, it is necessary to measure the antenna as a one port and tune by trimming or adding metal to it to center the minimum VSWR in the band. This approach only controls the one parameter of VSWR and does nothing for Gain or efficiency. That must be addressed by design. If the user's application requires a different stackup or material properties or adjacent components that may distort the RF response, then add a millimeter to the antenna length and plan on trimming to achieve acceptable Return Loss (-10 dB or less).

## 4.2 Antenna to 50 Ohms

Three methods may be employed to have the ability to measure the antenna separate from the matching network. 1) RF microswitch, 2) Alternate path to an SMA connector (as found on Freescale's MC13233-MRB) or 3) a pigtail made from coax soldered to the board.

1. An RF microswitch has been used on some Freescale's reference designs where the method to evaluate either the antenna or the radio performance is a special connector that snaps onto the microswitch. The microswitch placement is after all matching and filtering but before the antenna. The special connector is connected to an SMA connector via a microcoax cable. The limitations are that the switch is directional and a determination has to be made in advance of which direction the switch will throw when the special connector is attached. That is, it can be *looking* into the output of the radio when the special connector is inserted or it can be *looking* into the antenna but not both. A limited number of boards can be built for each direction so that both, the RF output of the radio can be evaluated and also the input of the antenna.
2. Microstrip to SMA. In order for our customers to evaluate some of our boards without having to do over the air measurements, we have included a microstrip line to a board edge SMA connector. The microstrip is selectable from the single ended side of the Balun on the antenna side of the harmonic trap (which is usually between the balun and the antenna). The microstrip line is selectable by using a capacitor rotated toward the SMA instead of toward the antenna. In that case, if the user is careful in the placement of the capacitor, instead of selecting between an RF output path of either the SMA connector or the antenna from the radio, the capacitor can be placed

across the connection of the SMA and the antenna. In that case, the SMA can be used to interrogate the VSWR of the antenna without any special connectors or special preparation of the board as is required when employing method 3.

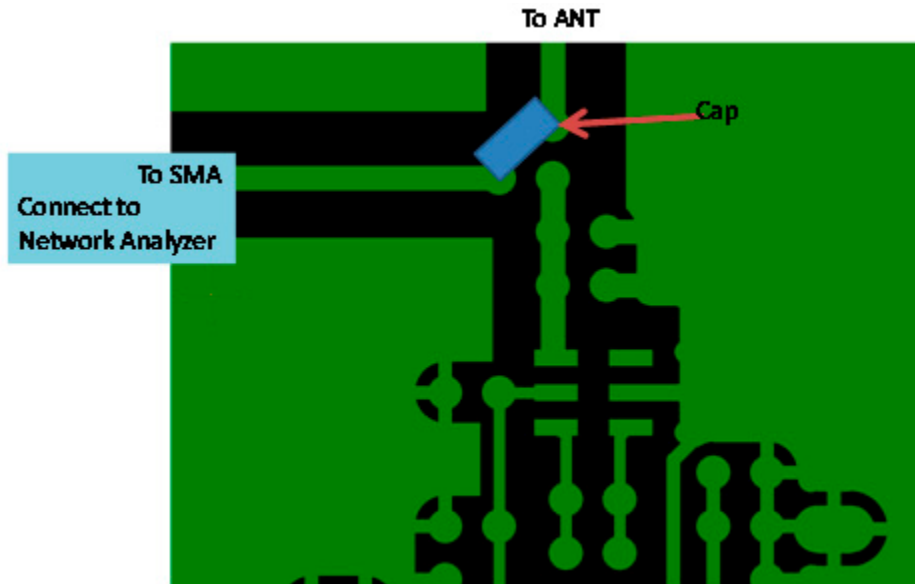

3. Pigtail. Often times, a customer does not want to incur the cost of a special microcoax connector and microswitch when only a few are needed for validation of design. Or it is not convenient to include an alternate path for SMA for their specific application. In this case, if a sufficient ground plane is available and the customer is careful to keep components clear, a piece of coax cable with an SMA connector on one end can be soldered to the board on the ground plane and the center pin attached to the antenna feed. Using this method does not lend itself to doing many boards but is useful for tuning and evaluating a few boards. If any serious quantity of boards is necessary for validation of design, then method 1 or 2 is recommended.

The most common antenna used by our customers is an inverted F antenna. This section describes how to tune an inverted F antenna feed impedance to achieve 50 Ohms characteristic impedance. It is a simple matter to tune an inverted F antenna to operate at the proper frequency. Ideally, the minimum return loss needs to be centered at about 2445 MHz. Generally, even if the frequency is offset a little, such that there is at least 10 dB return loss looking into the antenna at the band edges, is sufficient to achieve good range and receive sensitivity. Using one of the three methods outlined above, connect the antenna to a network analyzer. Adjust the bandwidth of the network analyzer display such that the natural point of resonance of the antenna is visible in the display window. Have the display view broad enough so that if the antenna resonance is a few hundred MHz low or high, it will still be in view. The purpose is to know whether to tune the antenna up in frequency or down in frequency. If the natural resonance is lower than the wanted band, then the antenna is too long for this application and can easily be tuned to center frequency by trimming the length. Take very small cuts on the length (for most of Freescale's designs this means the top and bottom sides of the substrate) and re-measure VSWR. Repeat this process until the antenna is centered in the band. If the natural resonance is higher than the wanted band, then the antenna is already shorter than needed for this band and copper foil will need to be added carefully to the antenna length to move the resonant point down in frequency. If foil must be added to increase the length, then add more than

necessary so that subsequent tuning can be done by the cutting process. After this is achieved, move onto the impedance matching exercise.

### 4.3 Impedance Matching Components

Due to the inaccessibility of many of our customers to expensive equipment, we do not give an elaborate method for matching using a simulator. Most of Freescale's radios are tolerant to minor board changes that customers require. However, a customer's board that may be a copy of a Freescale reference design may have a response that is not meeting performance parameters due to board parameter differences, application component interference or encapsulation. In that case, the customer board needs to be re-tuned to optimize RF performance. Freescale does not maintain a reference library for matching purposes. Instead, we provide reference designs that have proven to be robust when copied carefully. Usually, the values of components that are chosen for our boards need very little adjustment for our customer boards. Therefore, as a first step in re-tuning a customer's application board, simply replace the series matching inductors with the next incremental values up or down. Then measure and evaluate TX power, Error Vector Magnitude (EVM) and RX sensitivity. Also, there is usually a shunt capacitor or inductor across the differential outputs. Adjusting this value may be necessary also. Adjust the tuning values as necessary. Usually, the component values will not need to be modified by more than one increment up or down.

## 5 Antennas

### 5.1 Monopole Antennas

If one part of a dipole antenna is removed and replaced by an infinite ground plane, the remaining half of the dipole *mirrors* itself in the ground plane. This ground plane is sometimes referred to as the counterpoise.

For all practical purposes, the monopole behaves as a *half* dipole. That is, it has the same doughnut shaped radiation pattern, the radiation resistance is half that of the dipole (37 Ohm), it can be bent or folded like the dipole, and the same loading and feeding techniques can be applied.

However, one very important difference remains in that the antenna feed point is not balanced, but single ended. Because of this, and because most RF circuits are of the unbalanced type, this antenna type is very popular and a lot of variations of the monopole theme exist, most designed to match 50 Ohms.

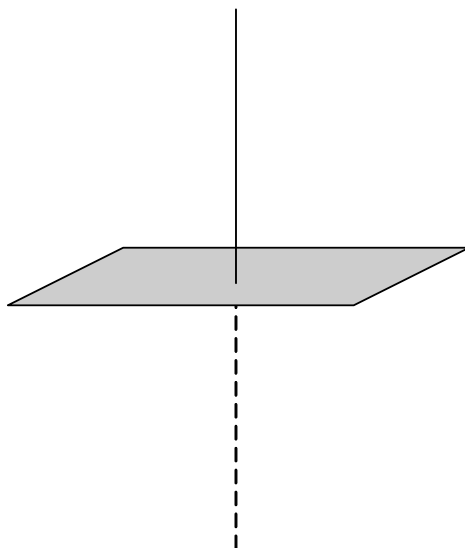

**Figure 1. Monopole Above a Ground Plane, Showing the Mirror Antenna**

It is important to note that the *whip* is only half the antenna and that the remainder is made up of the ground plane, or counter weight, as it is sometimes called. In a practical application, the ground plane is often made up of the remainder of the PCB (ground and supply planes, traces, and components) and/or the metal case of the device, if it has one.

The ground plane should be a reasonably sized area compared to the antenna, and should be as continuous as possible. If a monopole is used on a very small PCB, perhaps even with only a small area of copper, efficiency will suffer, and the antenna will be difficult to tune. Components and PCB tracks introduce additional losses and affect the feed point impedance.

As for the dipole, resonance is typically obtained at a length slightly shorter than  $1/4$  wavelength. The radiation resistance is changed by bending the antenna, and like the dipole, the nulls in the theoretical radiation pattern can be reduced. By bending the antenna elements, the radiation resistance and efficiency drops, so the antenna should not be placed too close to ground. Like the dipole, the monopole can also be folded and bent around corners, if board space requires this, or it can be loaded with series coils.

Of the many variations that exist, the following sections highlight the most common.

### 5.1.1 Open Stub, Tilted Whip

If the monopole is bent and traced along the ground plane, it will be more compact and the null in the radiation pattern is partly eliminated. The antenna should not be too close to ground, preferably not closer than  $1/10$  wavelength (1 cm), or efficiency suffers too much. At this close spacing, the radiation resistance is so low (in the order of 10 Ohms) that a matching network is usually needed. If the monopole is very close to ground, it will act as a transmission line instead of an antenna, with little or no radiation at all.

### 5.1.2 Inverted-F Antenna

The F-antenna can be thought of as a tilted whip, where impedance matching is accomplished by tapping the antenna at the appropriate impedance point along its width. This antenna is used extensively because



it is reasonably compact, has a fairly omnidirectional radiation pattern, good efficiency, and is very simple. Note that the currents in the ground leg are high and that an adequate ground plane is necessary to provide good efficiency.

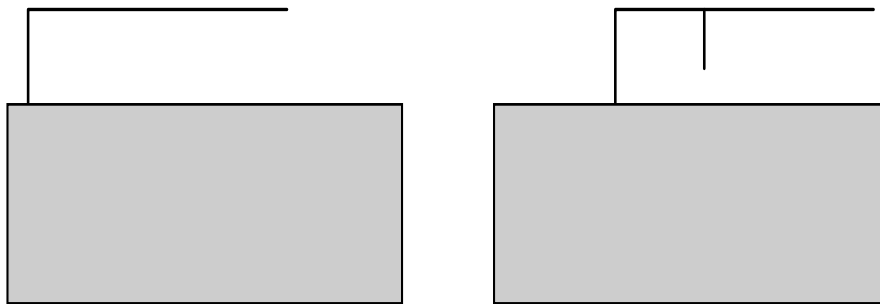

Figure 2. Tilted Whip and F-Antenna (Note the Ground Plane Area)

### 5.1.3 Meander Antenna

The meander antenna or meander pattern, is an antenna with the wire folded back and forth where resonance is found in a much more compact structure than can otherwise be obtained.

The meander, spiral, and helix antennas are similar in that resonance is obtained in a compact space by compressing the wire in different ways. In all three cases, the radiation resistance, bandwidth, and efficiency drops off as size is decreased, and tuning becomes increasingly critical. Impedance matching can be implemented by tapping much like tapping is accomplished in the F-antenna. The meander and helix antenna, or a combination of these two, are easily implemented in a PCB and also many ceramic chip antennas are based on these types of antenna.

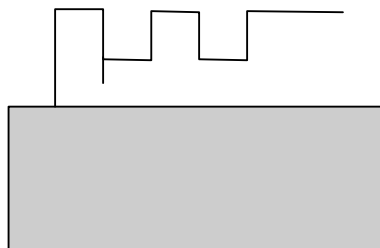

Figure 3. Meander Pattern (Tapped for Impedance Match)

## 5.2 Component Antennas

### 5.2.1 Chip Antennas

Numerous commercial chip antennas are available. At first glance, chip antennas appear to work for no apparent reason. However, careful investigation reveals that most of these antennas are based on a helix, meander, or patch design. To ensure proper operation, it is very important to follow the manufacturer's recommendations regarding footprint, ground areas, and mounting of the chip antenna. The *keep out* area around the antenna is especially important. Even following the recommendations does not always guarantee good performance due to de-tuning by nearby objects. It is expected that fine tuning of the antenna and/or a matching network is required to ensure satisfactory performance. Because chip antennas

normally, but not always, use a ceramic material with higher dielectric constant and lower loss than the usual FR4, it is possible to build smaller antennas with reasonable efficiency.

Efficiency is not exceptionally high and is typically in the range of 10-50%, which corresponds to 3-10 dB loss (-3 to -10 dBi). The lower number being inferior products with high inherent losses. As already stated, buying a chip antenna does not guarantee good performance. However, while they provide the smallest antenna solution possible, the size reduction comes at a cost both in performance and pricing.

If a slightly larger PCB area is available than is required by the chip antenna and the *keep out* area can be allocated to a PCB antenna, it is possible to implement a PCB antenna with the same or better performance than a chip antenna.

## 6 Miniaturization Trade-offs

### 6.1 Antenna Size

As previously stated, reducing antenna size results in reduced performance. Some of the parameters that suffer are:

- Reduced efficiency (or gain)
- Shorter range
- Smaller useful bandwidth
- More critical tuning
- Increased sensitivity to component and PCB spread
- Increased sensitivity to external factors

Several performance factors deteriorate with miniaturization, but some antenna types tolerate miniaturization better than others. How much a given antenna can be reduced in size depends on the actual requirements for range, bandwidth, and repeatability. In general, an antenna can be reduced to half its natural size with moderate impact on performance. However, after a 1/2 reduction, performance becomes progressively worse as the radiation resistance drops off rapidly. As loading and antenna losses often increase with reduced size, it is clear that efficiency drops off quite rapidly.

The amount of loss that can be tolerated depends on the range requirements. Bandwidth also decreases, which causes additional mismatch losses at the band ends. The bandwidth can be increased by resistive loading, but this often introduces even more loss than the mismatch loss. The low bandwidth combined with heavy loading requires a spread analysis to ensure adequate performance with variations in component values and PCB parameters. So, it is often better not to reduce antenna size too much if board space allows. Even if range requirements do not require optimum antenna performance, production problems and spread are minimized. It is also best to keep some clearance between the antenna and nearby objects. Although the antenna may be retuned to compensate for the loading introduced by the surrounding objects, tuning becomes more critical, and the radiation pattern can be heavily distorted.

### 6.2 Baluns

Many of the antennas already mentioned in this note are single-ended and designed to have a feed point impedance close to 50 Ohms. A balun is required to interface these antennas to a balanced output/input.

The balun converts a single ended input to a balanced output together with an optional impedance transformation. The output is differential. That is, the output voltage on each pin is of equal magnitude, but of opposite phase. The output impedance is normally stated as the differential impedance. That is, measured between the two output pins. The balun is bidirectional. The balanced port can be both input or output.

Several discrete circuits are available that perform as baluns but most of them are sensitive to input and output loading and PCB layout issues, which requires cumbersome fine tuning. Also, all of these require at least two chip inductors. In the 2.4 GHz band, there are small ceramic baluns that are easy to use and are less sensitive to the PCB layout with standard output impedances of 50, 100, and 200 Ohms.

The cost of a discrete balun is comparable to the ceramic balun and the ceramic balun requires less board space. Therefore, the ceramic balun is recommended for most designs.

## 7 Potential Issues

Numerous things can go wrong with an antenna design. The following list provides a few do's and don't's that may serve as a good checklist in a final design. Many of these items seem obvious to the experienced antenna designer, but many of these issues are routinely encountered in practice. This is obviously not a complete list.

- Never place ground plane or tracks underneath the antenna
- Never place the antenna very close to metallic objects
- In the final product, ensure that the wiring and components do not get too close to the antenna
- A monopole antenna will need a reasonable ground plane area to be efficient
- Do the final tuning in the end product enclosure, not in open air
- Never install a chip antenna in a vastly different layout than the reference design and expect it to work without tuning
- Do not use a metallic enclosure or metallized plastic for the antenna
- Test the plastic casing for high RF losses, preferably before production
- Never use low-Q loading components, or change manufacturer without retesting
- Do not use very narrow PCB tracks. The tracks should be relatively wide as space allows

## 8 Recommended Antenna Designs

The recommendation for antenna design employed by Freescale for ZigBee compliant hardware includes two substrate antenna designs and a chip component design:

1. Inverted-F antenna for best range performance
2. Meander antenna for reduced size
3. Chip Antenna for rapid time-to-market

Freescale's family of integrated ZigBee solutions has differential RF inputs and outputs. All recommended antenna designs have a 50 Ohm, single ended interface. Therefore, a balun interface between the 50 Ohm single ended antenna and the differential RF terminals is required for all but the 50 Ohm I/O port available

exclusively on the MC1322X radio. The performance advantage of a design such as Freescale’s Inverted-F antenna, often make this the preferred approach.

The Inverted-F antenna has its limitations where board space is critical. If range is not an issue then, the trade off of space for range can be employed by a meandering inverted-F antenna. The inverted-F and consequently, the meandering inverted-F antenna is a directional antenna and orientation of the antenna on the board will affect the range. This is usually not a big concern for well tuned radios that only need to operate within a relatively small space such as a living room where the radio is being employed as a remote control.

While the inverted-F and meandering inverted-F antennas represent the lowest cost options for antennas, they are not necessarily the best choice for time-to-market due to the need to tune them. If the time frame to move the end product into the market place is paramount, then employing the chip antenna for early production can generate revenue while a less expensive board level inverted-F antenna can be developed and implemented as a cost reduction measure.

## 9 Design Examples

The following section shows a series of design examples. Each of these has been tuned for a particular design, so a cut-and-paste approach will not necessarily ensure optimum performance. However, these designs are a good starting point for further optimization, and they indicate the approximate size of the particular antenna.

### 9.1 Inverted-F Antenna

The following figure shows an F-antenna. Measurements are in millimetres.

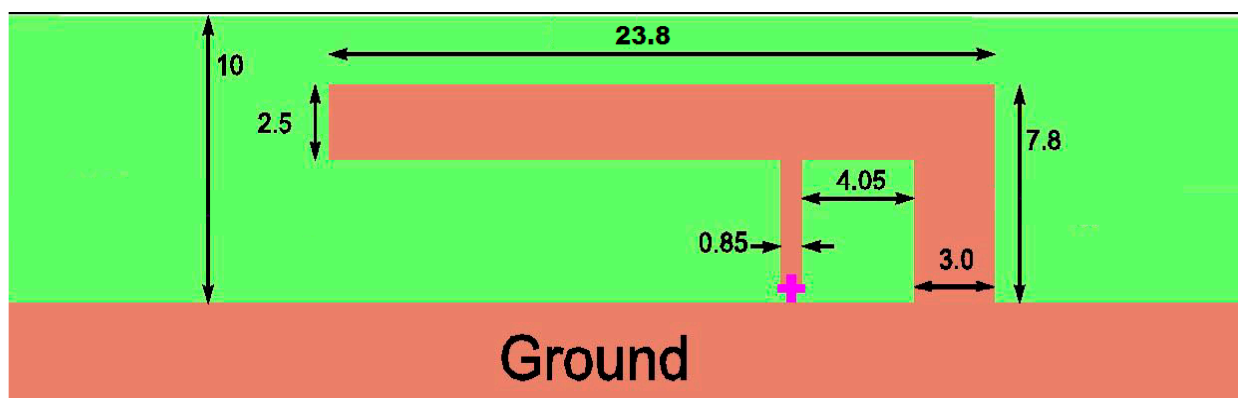
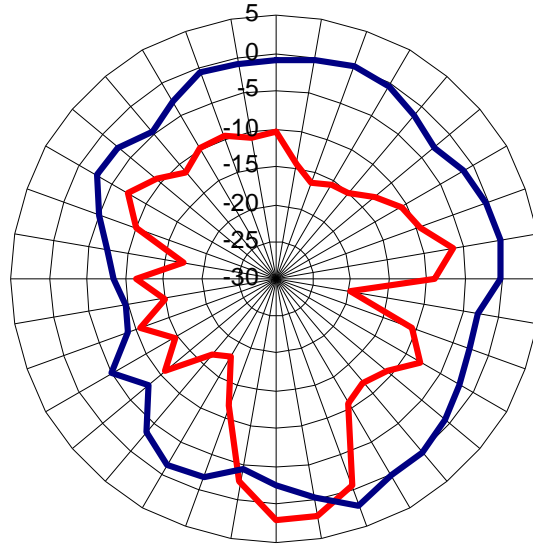

Figure 4. F Antenna

Figure 5 shows the EVK horizontal PCB radiation pattern. Red represents vertical polarization and blue represents horizontal polarization both measured in dBi.



**Figure 5. F-Antenna Radiation Pattern (For Antenna as Shown in Figure 11)**

Figure 6 shows a typical plot of the return loss and bandwidth obtainable with an F-antenna. A slight ripple is caused by the ground plane size.

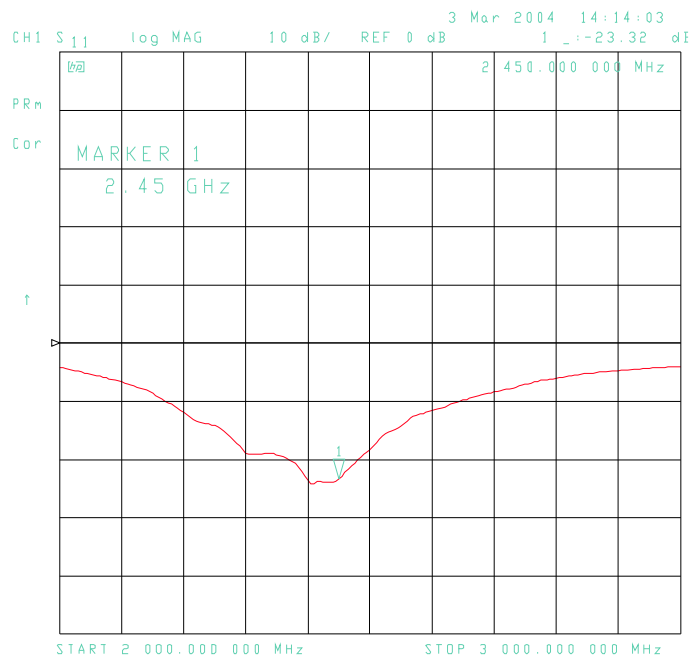

**Figure 6. F Antenna Return Loss and Bandwidth**

## 9.2 Chip Antennas

Numerous chip antenna designs exist and Freescale strongly recommends carefully following the antenna manufacturers guidance regarding ground, keep-out areas, etc.

## Design Examples

With no tuning, chip antennas often have a resonant frequency above 2.5 GHz and the return loss at 2.45 GHz is very poor. The antenna must be tuned either by inserting a chip coil in series with the feed point, or adding a PCB track to the opposite end to lower the resonant frequency to 2.45 GHz. The antenna needs to be tuned for the PCB and enclosure that the end product will have.

**How to Reach Us:**

**Home Page:**  
[freescale.com](http://freescale.com)

**Web Support:**  
[freescale.com/support](http://freescale.com/support)

Information in this document is provided solely to enable system and software implementers to use Freescale products. There are no express or implied copyright licenses granted hereunder to design or fabricate any integrated circuits based on the information in this document.

Freescale reserves the right to make changes without further notice to any products herein. Freescale makes no warranty, representation, or guarantee regarding the suitability of its products for any particular purpose, nor does Freescale assume any liability arising out of the application or use of any product or circuit, and specifically disclaims any and all liability, including without limitation consequential or incidental damages. "Typical" parameters that may be provided in Freescale data sheets and/or specifications can and do vary in different applications, and actual performance may vary over time. All operating parameters, including "typicals," must be validated for each customer application by customer's technical experts. Freescale does not convey any license under its patent rights nor the rights of others. Freescale sells products pursuant to standard terms and conditions of sale, which can be found at the following address: [freescale.com/SalesTermsandConditions](http://freescale.com/SalesTermsandConditions).

Freescale and the Freescale logo are trademarks of Freescale Semiconductor, Inc., Reg. U.S. Pat. & Tm. Off. All other product or service names are the property of their respective owners. ARM and Cortex are registered trademarks of ARM Limited (or its subsidiaries) in the EU and/or elsewhere. All rights reserved.

© 2005, 2006, 2012, 2015 Freescale Semiconductor, Inc.

Document Number: AN2731  
Rev. 3  
09/2015

